

WINCH KIT



P/N 2883828

APPLICATION

Verify accessory fitment at Polaris.com.

BEFORE YOU BEGIN

Read these instructions and check to be sure all parts and tools are accounted for. Please retain these installation instructions for future reference and parts ordering information.

KIT CONTENTS

NOTE

Winch Kit 2883828 also contains Wireless Winch Remote Kit 2879316 (i.e., a kit within a kit).

Winch Kit 2883828 includes:

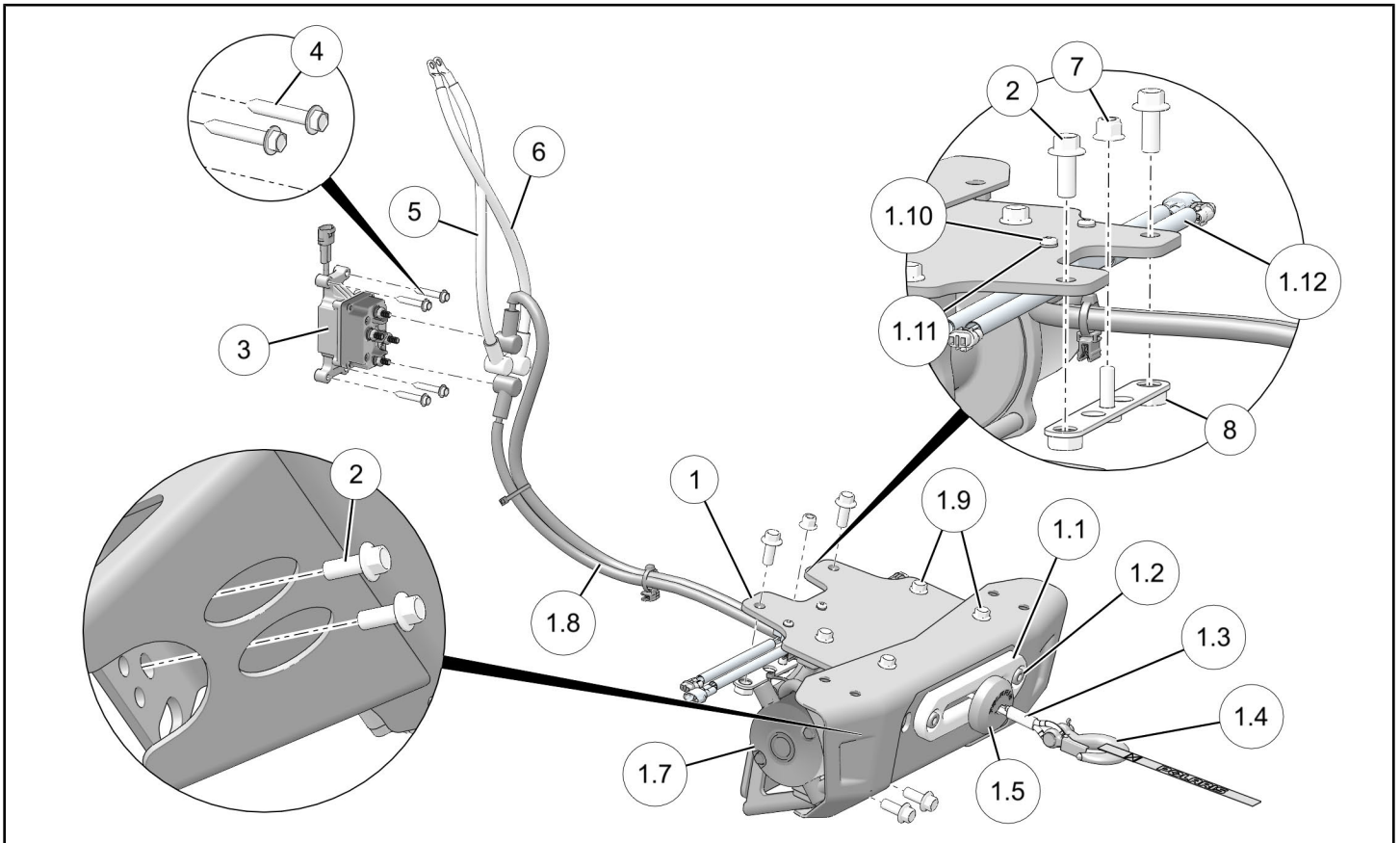

REF	QTY	PART DESCRIPTION	PART NUMBER
1	-	Winch Assembly (includes items 1.1–1.12)	-
1.1	1	- Fairlead	2883958
1.2*	2	- Screw, Socket Cap - M10 X 1.5 X 25	7517358 / 2883958
1.3	1	- Rope, UHMW	2879187
1.4	1	- Hook	2411836
1.5	1	- Stop, Magnetic	2883958

REF	QTY	PART DESCRIPTION	PART NUMBER
1.6	1	- Plate, Fairlead Backer (not shown)	5260831
1.7	1	- Winch, Motor Assembly, 4500 lb**	2207742
1.8	1	- Cables, Winch-to-Contactor	4017690
1.9*	4	- Screw, Hex Flange - M8 X 1.25 X 20	7519133
1.10*	2	- Screw, Torx® Pan Head, High/Low - #10 X 3/4	7512026
1.11*	2	- Washer - M5	7556724
1.12	1	- Controller, Autostop	2414731 / 2883958
2*	4	Screw, Hex Flange - M10 X 1.5 X 25	7518908
3	1	Contactor	4015095
4*	4	Screw, Hex Flange, High/Low - M6 X 35	7519330
5	1	Cable, Contactor-to-Terminal Block, Red	4013471-370
6	1	Cable, Contactor-to-Terminal Block, Black	4013470-375
7*	1	Nut, Hex Flange, Locking - M8 X 1.25	7547332
8	1	Plate, Winch Backer	5265335-458
9*	10	Cable Tie, 11 inch (not shown)	7080492
10	-	(unused)	-
	1	Winch User Guide	9923644
	1	Instructions	9929010

Items marked (*): Included in Hardware Kit PN 2207617.

Item marked (**): Replacement Rapid Rope Recovery gear selector knob PN 2207842.

Wireless Winch Remote Kit 2879316 includes:

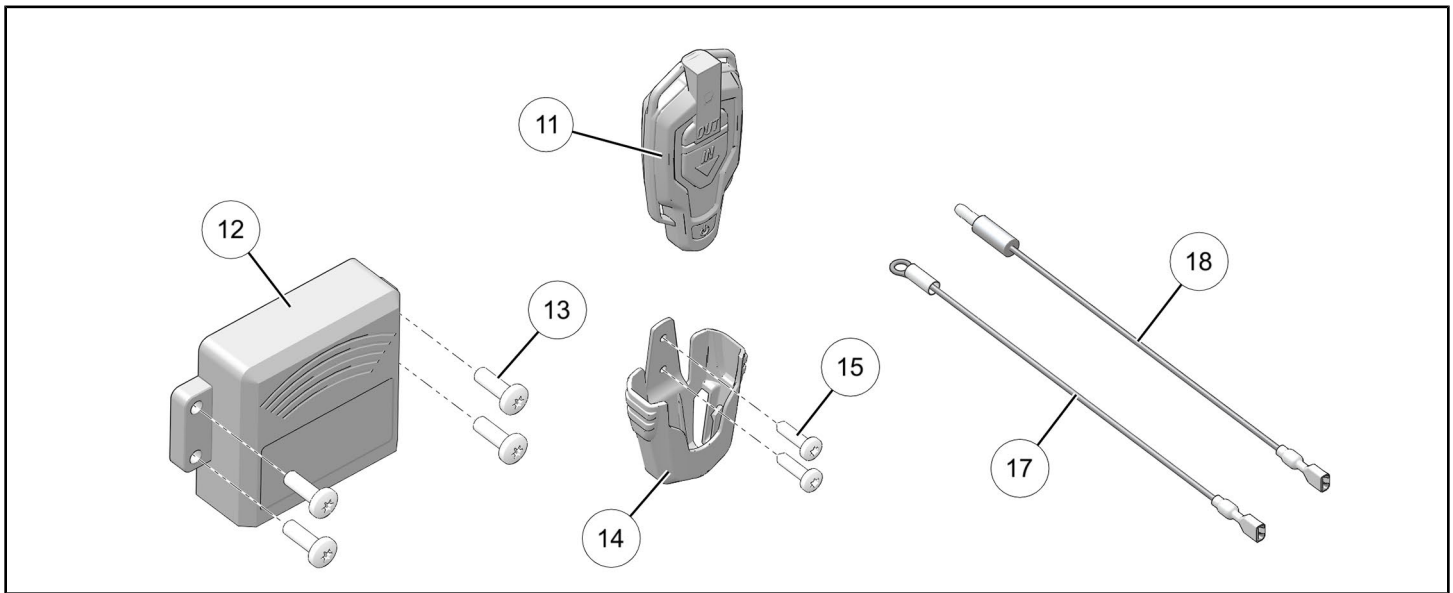

REF	QTY	PART DESCRIPTION	PART NUMBER
11	1	Remote, Wireless	-
12	1	Receiver, Wireless (wire harnesses not shown)	-
13*	4	Screw, Torx® Pan Head, High/Low - #14 X 0.75	7519731
14	1	Holder, Wireless Remote	5454269
15	2	Screw, Torx® Pan Head, High/Low - #10 X 0.75	7512026
16	1	Harness, Y-Splitter (not shown)	4017126
17	1	Wire, Adapter, Spade Terminal to Ring Terminal	-
18*	1	Wire, Adapter, Spade Terminal to Bullet Terminal	-

Items marked (*): Not used for installation of Winch Kit 2883828.

TOOLS REQUIRED

- Safety Glasses
- Drill
- Drill Bit: 1/8 inch (3 mm)
- Hole Saw: 1 inch (25 mm)
- Screwdriver Set, Torx®
- Socket Set, Metric
- Torque Wrench
- Wrench Set, Metric

IMPORTANT

Your Winch Kit is exclusively designed for your vehicle. Please read the installation instructions thoroughly before beginning. Installation is easier if the vehicle is clean and free of debris. For your safety, and to ensure a satisfactory installation, perform all installation steps correctly in the sequence shown.

ASSEMBLY TIME

Approximately 60 minutes

NOTE
Additional time may be required to accommodate other installed accessories.

HARNESS DETAIL

WINCH KIT 2883828

WINCH ①:

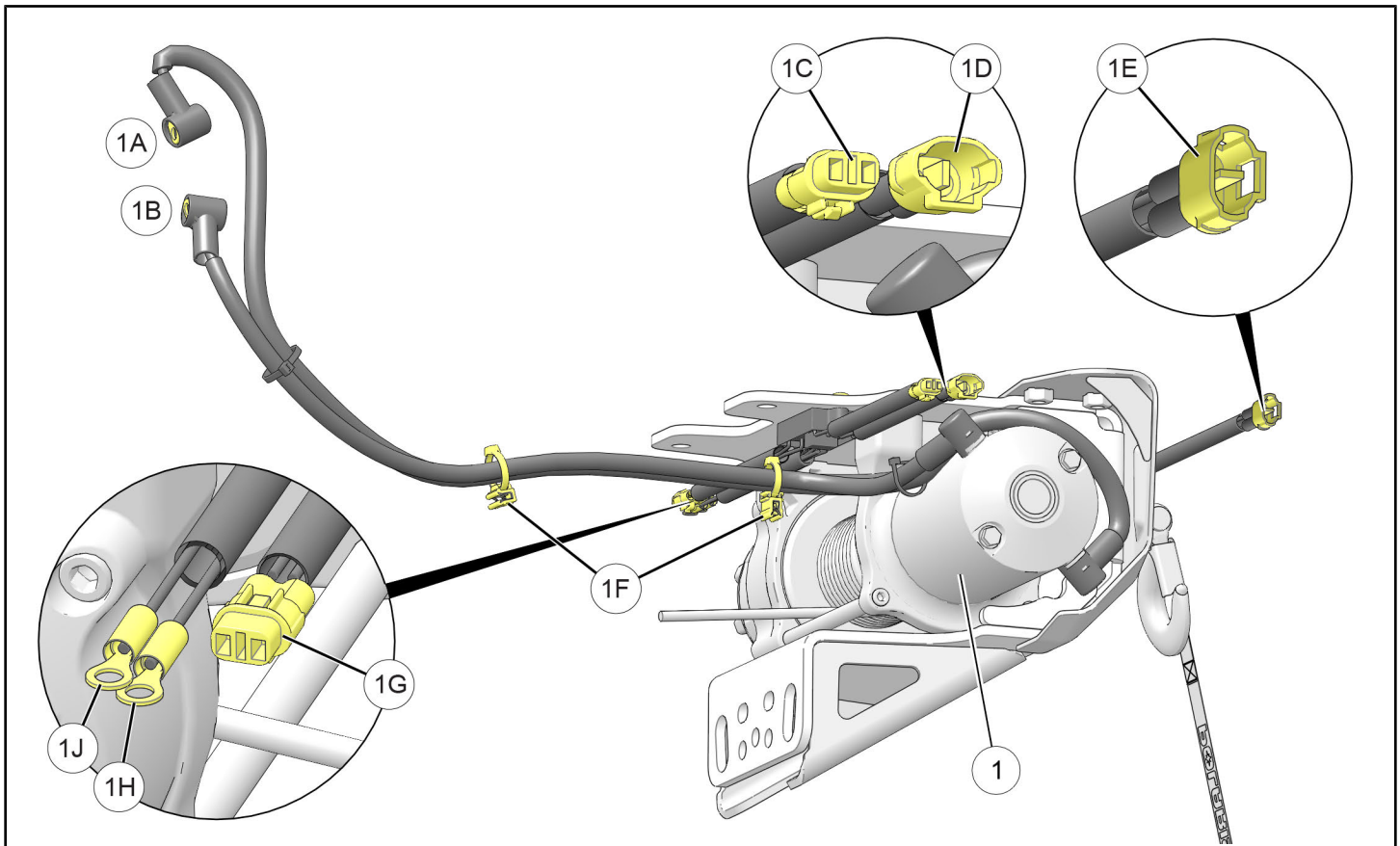

REF	PART DESCRIPTION	WIRE COLOR	PIN QTY/ GENDER	CONNECTS TO
1A	Ring Terminal, Contactor, with Boot - 1/4 inch (6 mm)	Yellow	-	Contactor ③, post 3B
1B	Ring Terminal, Contactor, with Boot - 1/4 inch (6 mm)	Blue	-	Contactor ③, post 3E
1C	Connector, Autostop Controller	-	2 female	Contactor ③, connector 3A
1D	Connector, Autostop Controller	-	2 male	Y-splitter ⑩, connector 16A
1E	Connector, Autostop Fairlead	-	2 male	PRE-CONNECTED to 1G
1F	Clip, Edge	-	-	Vehicle structure
1G	Connector, Autostop Controller	-	2 female	PRE-CONNECTED to 1E
1H	Terminal, Ring	Black	-	Terminal block negative (-); post may be identified as "GND"
1J	Terminal, Ring	Orange	-	Terminal block key power; post may be identified as "ACC"

CONTACTOR ③:

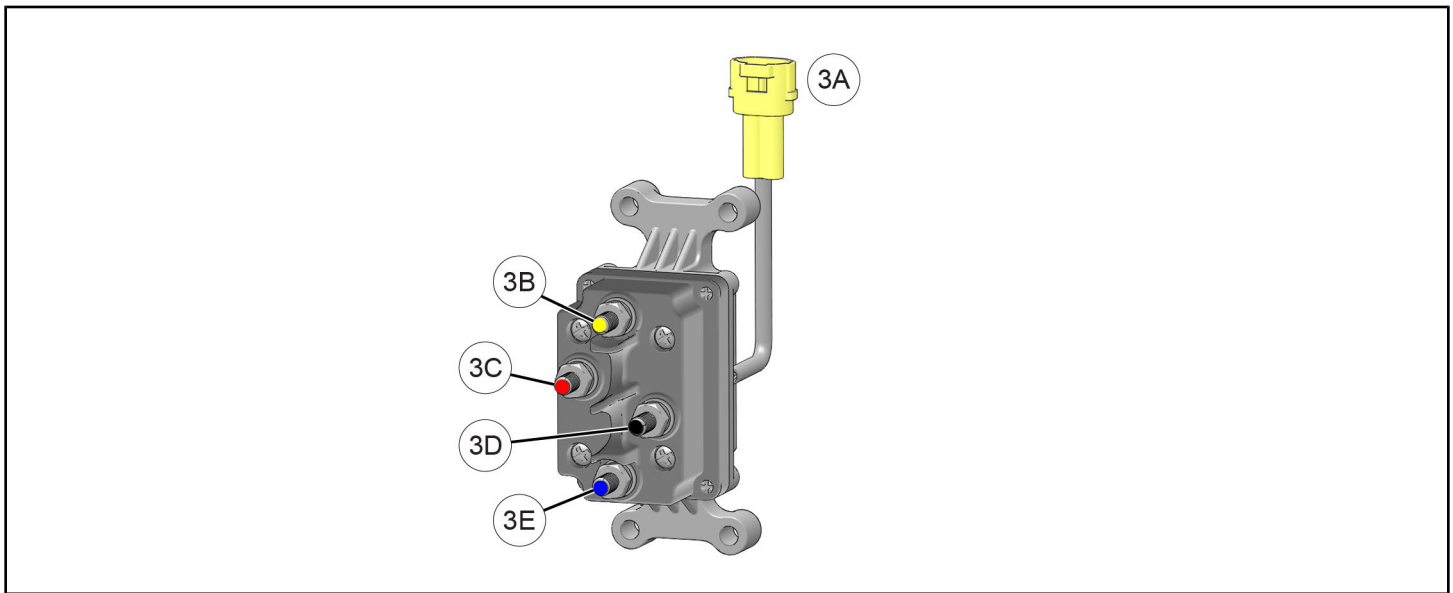

REF	PART DESCRIPTION	POST COLOR	PIN QTY/ GENDER	CONNECTS TO
3A	Connector, Wired Remote Socket	-	2 male	Winch ①, connector 1C
3B	Post, Winch	Yellow	-	Winch ①, ring terminal 1A
3C	Post, Terminal Block, Battery Positive (+)	Red	-	Cable ⑤
3D	Post, Terminal Block, Battery Negative (-) / Ground	Black	-	Cable ⑥
3E	Post, Winch	Blue	-	Winch ①, ring terminal 1B

WIRELESS WINCH REMOTE KIT 2879316

WIRELESS RECEIVER ⑫:

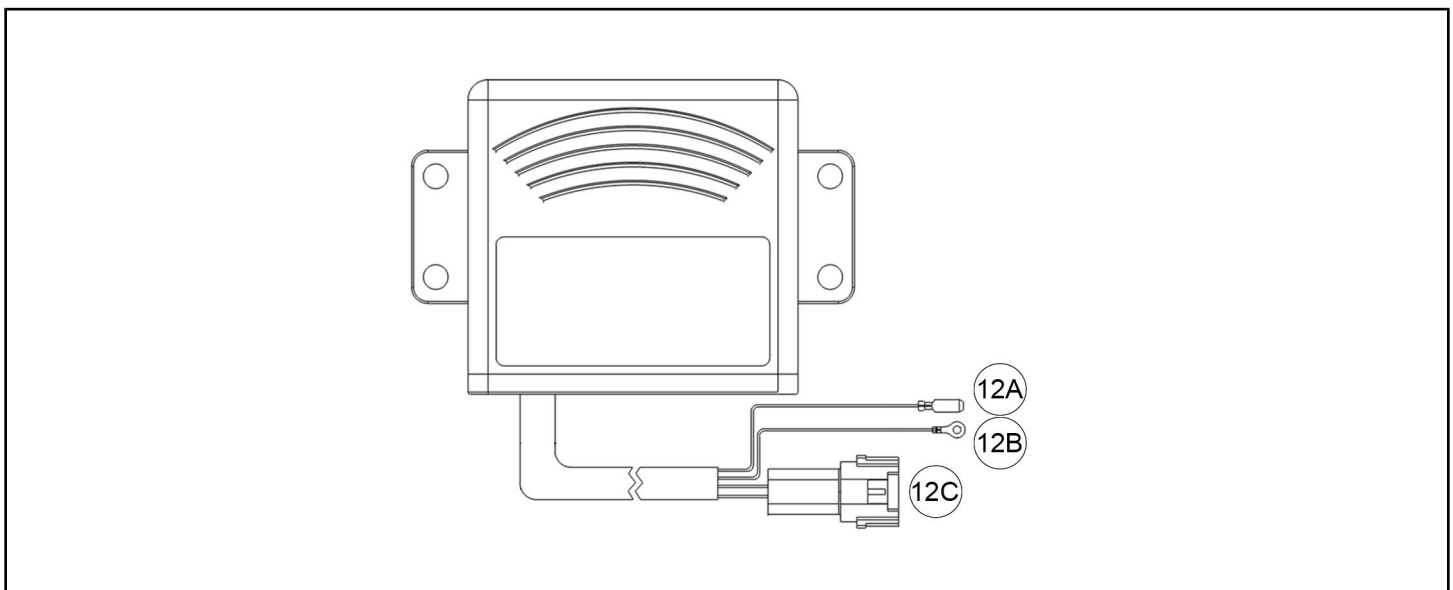

REF	PART DESCRIPTION	WIRE COLOR	PIN QTY/ GENDER	CONNECTS TO
12A	Terminal, Spade	Orange	1 male	Adapter wire ⑰, connector 17A
12B	Terminal, Ring	Black	-	Terminal block negative (-); post may be identified as "GND"
12C	Connector	-	2 male	Y-splitter harness ⑯, connector 16B

Y-SPLITTER HARNESS ⑯:

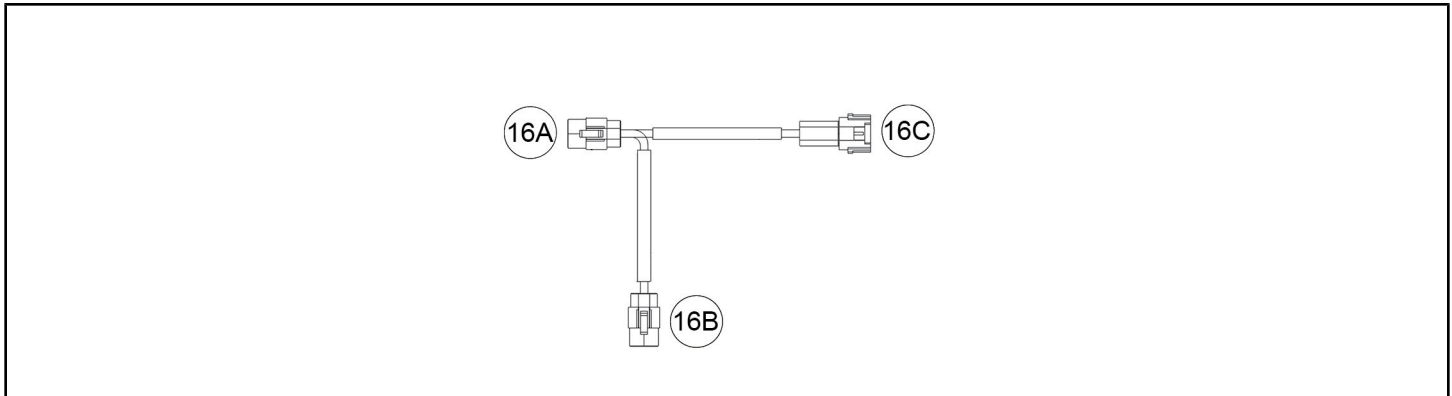

REF	PART DESCRIPTION	WIRE COLOR	PIN QTY/ GENDER	CONNECTS TO
16A	Connector	-	2 female	Winch ①, connector 1D
16B	Connector	-	2 female	Wireless receiver ⑫, connector 12C
16C	Connector	-	2 male	Nothing (connector not used in this application)

ADAPTER WIRE ⑰:

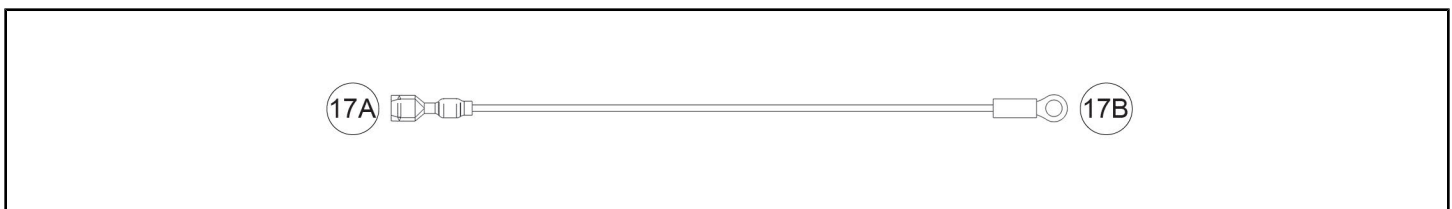

REF	PART DESCRIPTION	WIRE COLOR	PIN QTY/ GENDER	CONNECTS TO
17A	Terminal, Spade	Orange	1 female	Wireless receiver ⑫, connector 12A
17B	Terminal, Ring	Orange	-	Terminal block key power; post may be identified as "ACC"

INSTALLATION INSTRUCTIONS

IMPORTANT

Carefully read **GEAR SELECTION** section at end of manual to familiarize yourself with proper operation of Rapid Rope Recovery function.

1. Shift vehicle transmission into "PARK". Turn ignition switch to "OFF" position and remove key.
2. Remove driver's (or left rear passenger) seat and disconnect black negative (-) cable from battery.
3. Gain access.
 - a. Remove hood.
 - b. Remove grille by carefully depressing two tabs **(A)** at top of grille, then tilt grille forward to detach two lower tabs from fascia.

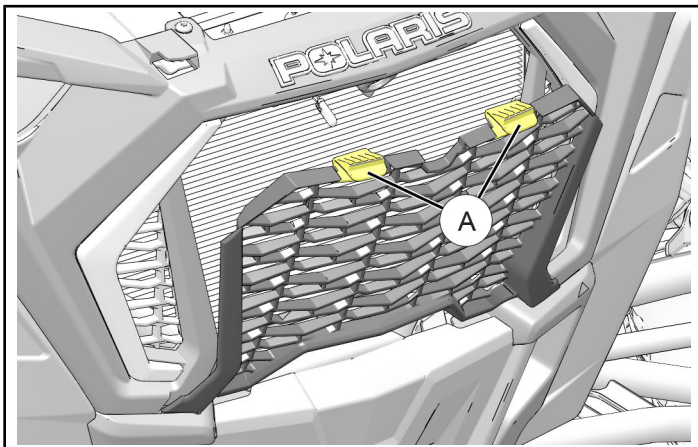

- c. Remove winch cover by removing two screws **(B)**. Tilt and lift grille to detach two upper tabs **(C)** from fascia. Cover and screws will not be reused.

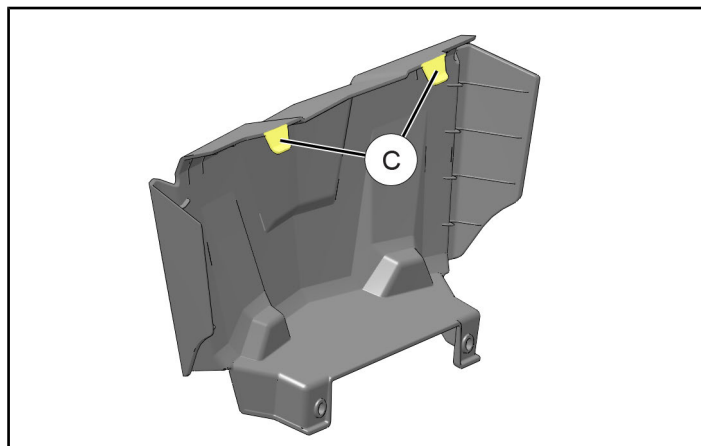
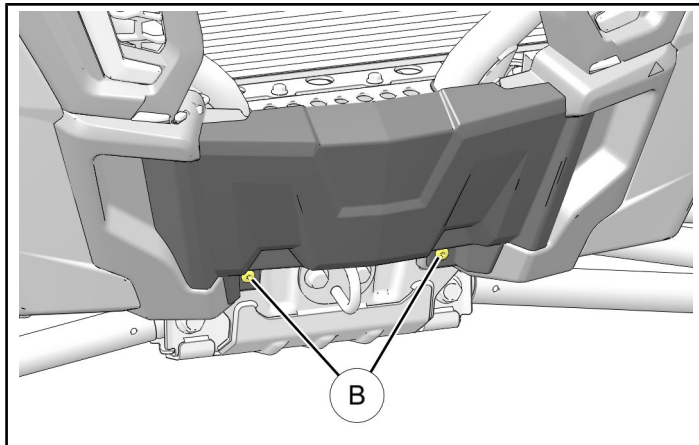

- d. Reaching through left front wheel well, apply tape to secure tow hook backer plate **(D)** (hanging from chassis structure), then remove tow hook by removing two screws **(E)**. Hook and screws will not be reused.

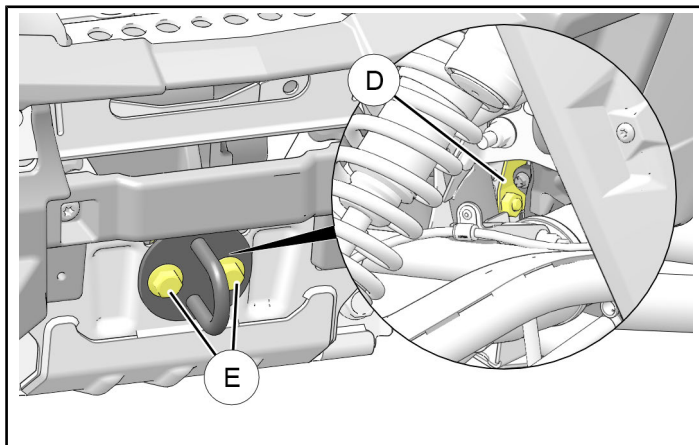

4. Install winch assembly.
 - a. Install winch backer plate ⑧ to underside of support channel ⑥ using nut ⑦. Align holes in plate and channel, then tighten nut.

NOTE

Support channel shown transparent for clarity.

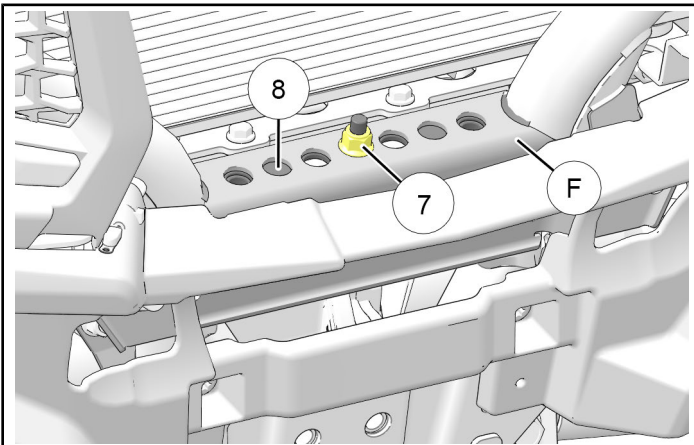
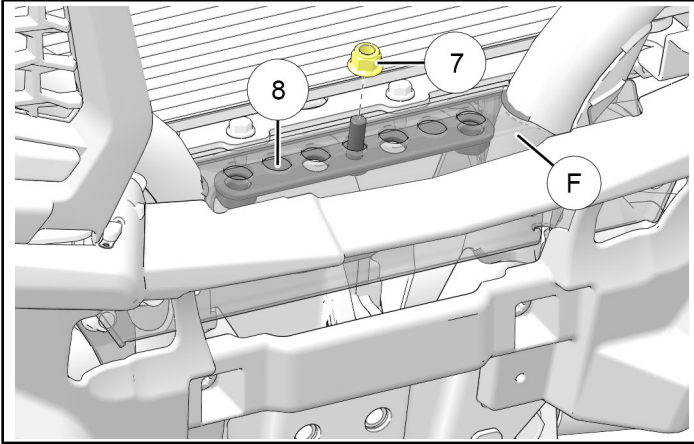

- b. Lift winch assembly ① into position at front of vehicle, route contactor ring terminals 1A and 1B through opening in support channel ⑥, then secure cables to channel using edge clip 1F.

NOTE

See previous section, **HARNESSES DETAIL**, for connector identification.
Winch assembly hidden for clarity.

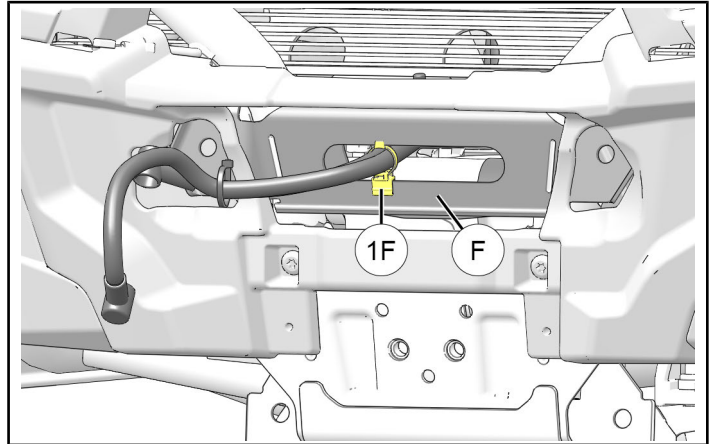

- c. Loosely install upper end of winch assembly ① to vehicle using two screws ②.

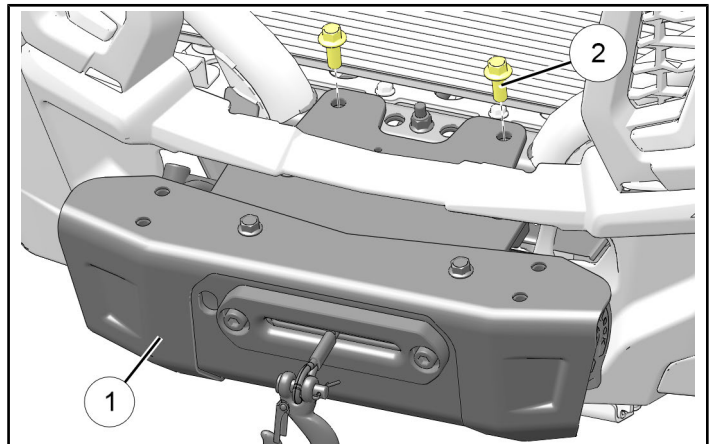

- d. Install lower end of winch assembly ① to vehicle using two screws ②.

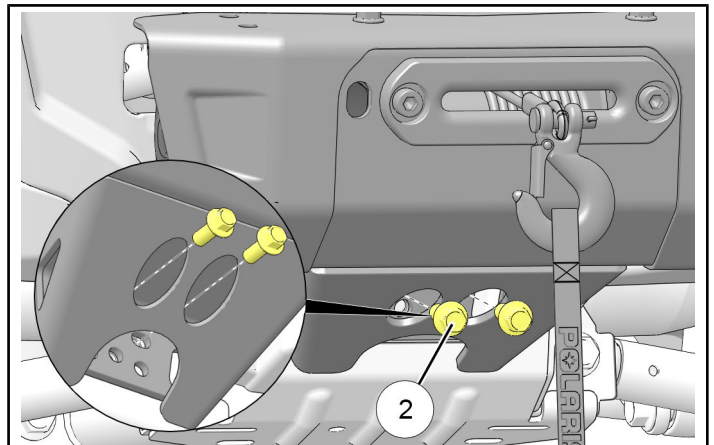

e. Torque all four screws ② to specification.

TORQUE

40 ft. lbs. (54 Nm) ± 10%

- f. Connect cables ⑤ and ⑥ to posts on contactor ③. Ensure cables are oriented upwards as shown. Do not remove existing wire and ring terminal (not shown) from **BLACK** post 3D.
- RED** cable ⑤ to **RED** post 3C
 - BLACK** cable ⑥ to **BLACK** post 3D
- Tighten nuts, then install cable boots.

NOTE

See previous section, **HARNES DETAIL**, for connector identification.
Cable boots hidden for clarity.

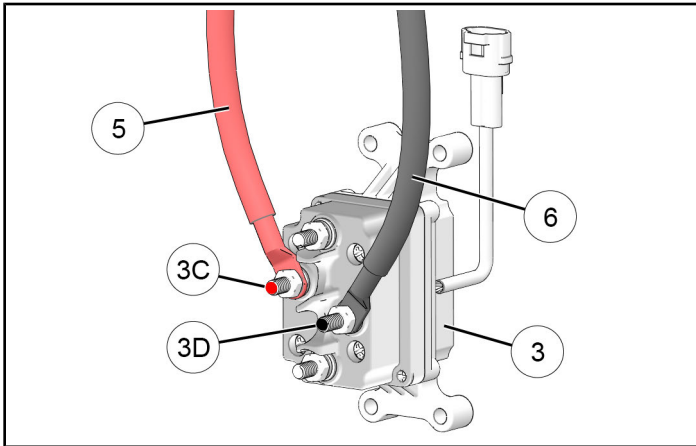

- g. Place contactor ③ near firewall in approximate location shown. Do not install contactor to firewall at this time.

NOTE

View looking inboard from right front wheel well. Some components hidden or shown transparent for clarity.

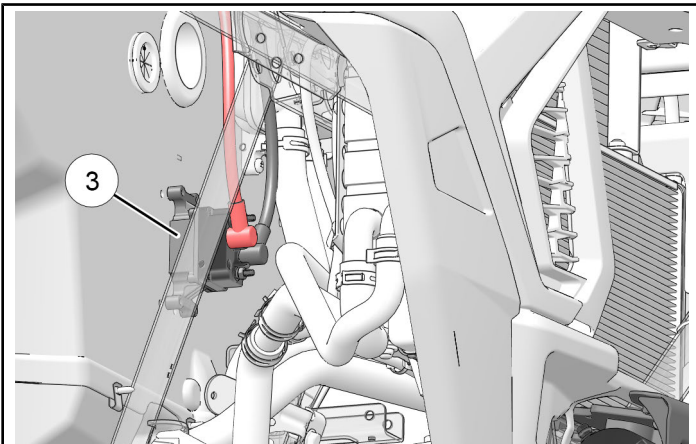

- h. Connect winch ring terminals 1A and 1B to posts on contactor ③. Ensure final cable routing (with contactor installed to firewall) will prevent contact with hot components, sharp edges, or moving parts.

- Ring terminal 1A (**YELLOW** cable) to **YELLOW** post 3B
- Ring terminal 1B (**BLUE** cable) to **BLUE** post 3E

Tighten nuts, then install cable boots.

NOTE

Cable boots hidden for clarity.

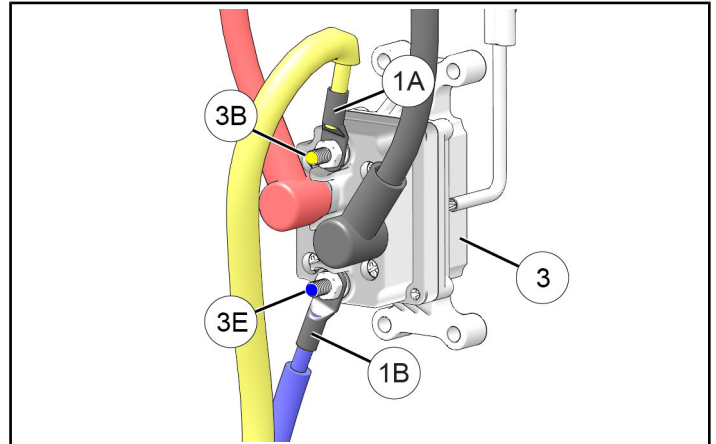

- Join connector 3A on contactor ③ to connector 1C on winch ①.

- j. Route loose ends of cables ⑤ and ⑥ upward, then connect ring terminals to terminal block. Install terminal block post nuts finger tight only. Additional connections will be made in next step.

Ensure final cable routing (with contactor installed to firewall) will prevent contact with hot components, sharp edges, or moving parts.

- i. **RED** cable ⑤ to post identified as **BAT** (with existing **RED** battery connection cable; unswitched 12V POS)
- ii. **BLACK** cable ⑥ to post identified as **GND** (with existing **BLACK** battery connection cable; 12V NEG)

NOTE

If two cable boots exist for same terminal, then slide inner boot (closest to terminal block) down cable. Unused boot can remain on cable.

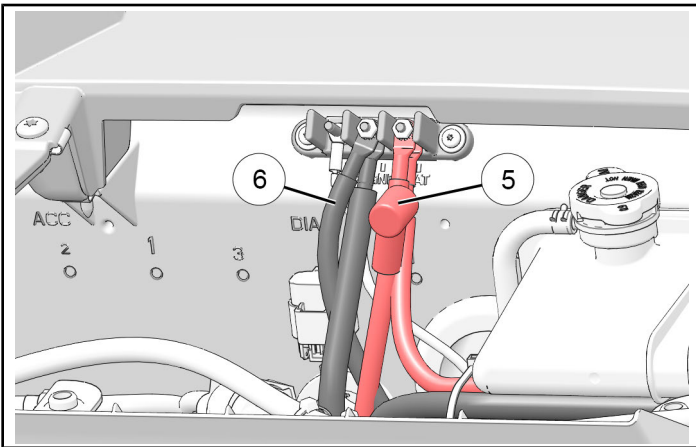

- k. Route two ring terminals 1H and 1J rearward and upward, then connect to terminal block. Install terminal block post nuts finger tight only. Additional connections will be made later.
- Ring terminal 1J (orange wire from winch ①) to post identified as **ACC** (with existing orange wire; key power 12V POS)
 - Ring terminal 1H (black wire from winch ①) to post identified as **GND** (with existing **BLACK** battery connection cable; 12V NEG)

- l. Install contactor ③ to pre-formed screw holes in firewall using four screws ④. Do not overtighten screws.

TIP

Install screws in the following sequence: upper RH (passenger side) screw, lower RH screw, then LH (driver side) screws.

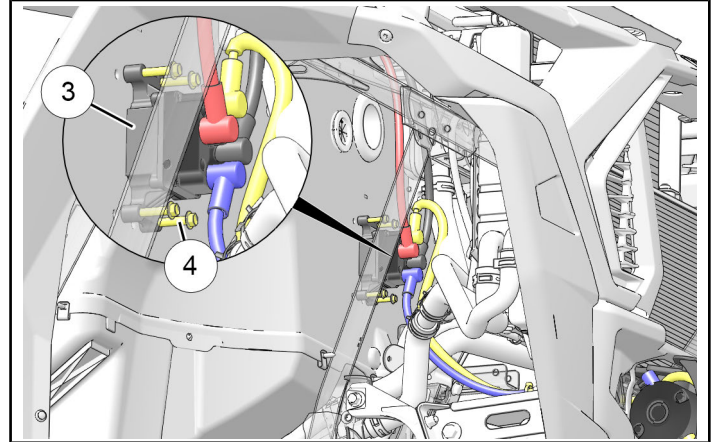

5. Install Wireless Winch Remote Kit 2879316 (included).

NOTE

See previous section, **HARNESS DETAIL**, for connector identification.

- a. Install wireless receiver.
- i. Install wireless receiver ⑫ on top of front drive mounting plate ⑥ using cable ties ⑨.

NOTE

View looking inboard from right front wheel well. Wheel hidden for clarity. Screws ⑬ are not used in this application.

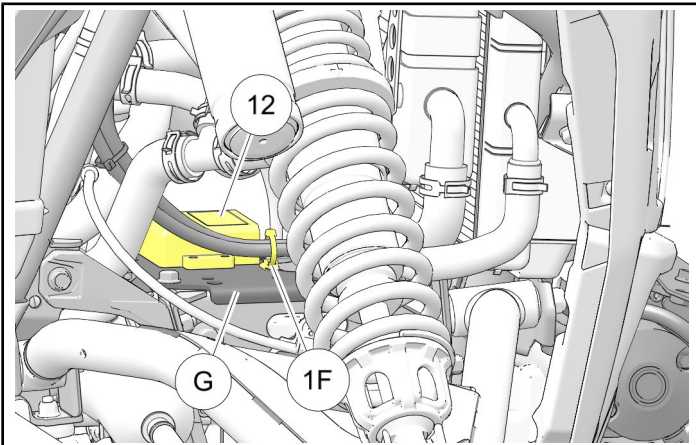

- ii. Secure winch-to-contactor cables to front of front drive mounting plate ⑥ using edge clip 1F, and at additional locations using cable ties ⑨ (locations as required to prevent cable contact with hot components, sharp edges, or moving parts).
- iii. Join connector 16A on Y-splitter harness ⑯ to connector 1D on winch ①.
- iv. Join connector 16B on Y-splitter harness ⑯ to connector 12C on wireless receiver ⑫.

NOTE

Connector 16C is not used in this application.

- v. Join spade terminal 12A on wireless receiver ⑫ to spade terminal 17A on adapter wire ⑰.

- vi. Route two ring terminals 12B and 17B upwards, then connect to terminal block.
- Ring terminal 17B (orange wire from adapter wire ⑰) to post identified as **ACC** (with existing orange wire; key power 12V POS)
 - Ring terminal 12B (black wire from wireless receiver ⑫) to post identified as **GND** (with existing **BLACK** battery connection cable; 12V NEG)
- vii. Torque all three terminal block post nuts (ACCY, GND, and BAT) to specification, then install cable boot(s).

TORQUE

24 in. lbs. (2.7 Nm) ± 10%

- b. OPTIONAL: Install wireless remote.

NOTE

Wireless remote ① can be stowed in any suitable location. Holder ④ is not required.

- i. Remove wireless remote ① from holder ④. Determine suitable mounting location for holder with special attention to the following:
- Driver operation of vehicle (including travel of controls, such as shift lever)
 - Driver visibility
 - Adequate clearance between holder mounting fasteners and other vehicle components on underside of mounting surface
- ii. Using holder ④ as template, mark and drill two 1/8 inch (3 mm) holes into mounting surface.

IMPORTANT

Control drill depth to prevent damage to underlying structure or components.

- iii. Install holder ④ using two screws ⑤. Do not over-tighten screws.
- iv. Reinstall wireless remote into holder.
6. Reinstall grille and hood. See Steps 3a-3b.
7. Reconnect black negative (-) cable to battery and reinstall seat.

OPERATION

OPERATIONAL CHECK

Wireless remote allows winch operation from outside the vehicle. If winch does not operate as described, refer to the **TROUBLESHOOTING** section.

IMPORTANT

The Autostop system is intended to prevent winch damage caused by over-tightening the rope, but cannot prevent all possible winch damage. The winch system is very powerful and care should be exercised whenever it is in operation.

The winch operator is always responsible for using the winch properly, as described in the accompanying "Winch User Guide". The Autostop system should only be used as a secondary preventive measure to help prevent damage to the winch from over-tightening the rope.

1. To turn wireless remote "ON", depress and hold power button for three seconds or until LED light illuminates.
2. To extend rope, depress and hold the "OUT" button. To recover rope, depress and hold the "IN" button.

IMPORTANT

During rope retraction the winch should automatically stop when the magnetic stop comes close to or contacts the autostop fairlead (within approximately 1 inch (25 mm)). Magnets in the stop trigger sensors in the fairlead, stopping the winch.

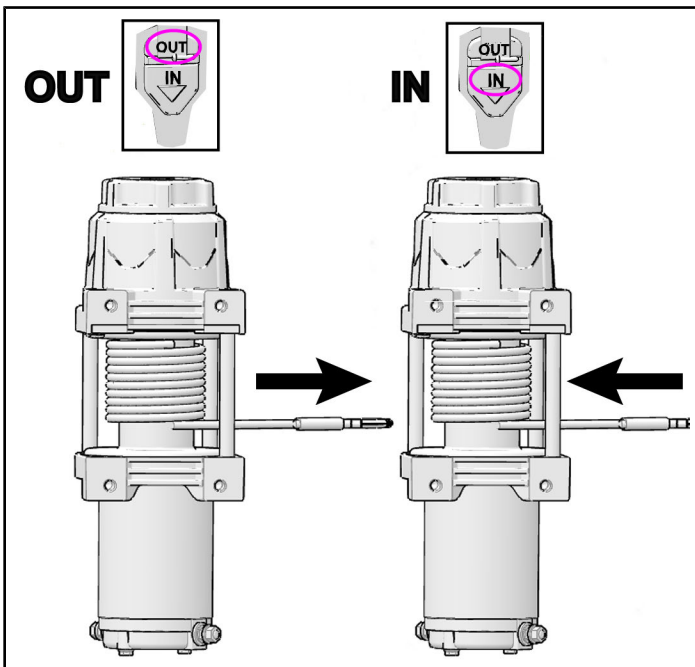

3. The wireless remote will automatically turn "OFF" after 30 seconds of inactivity. To manually turn off, depress and hold power button for three seconds or until LED light extinguishes.

GEAR SELECTION

WARNING

Do NOT attempt to change gear setting while rope is under tension. Failure to relieve rope tension prior to changing gears may result in winch failure, resulting in serious personal injury or death.

NOTE

See Kit Contents for replacement knob PN.

Your winch is equipped with three different gear settings: "N" (NEUTRAL), "L" (LOW), and "H" (HIGH).

1. NEUTRAL: Used to rapidly extend the rope.

When in neutral "N" will be visible in the cutout window on the shift knob (LH side of winch).

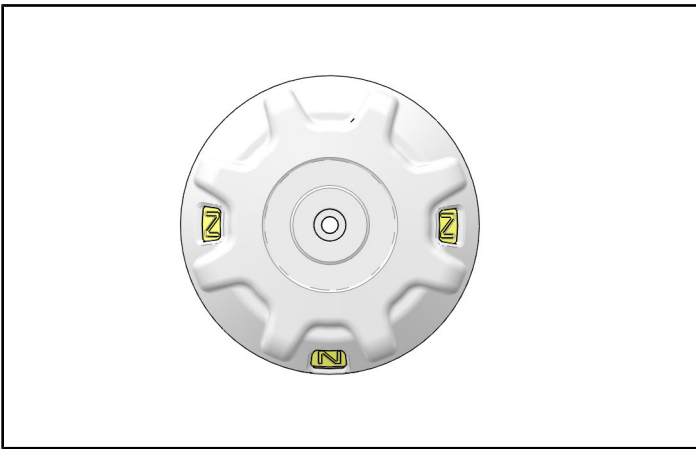

2. LOW: Used to recover the LOADED rope.

Relieve all tension from the rope, then rotate gear select knob counter-clockwise until "L" is visible in the shift knob cutout window.

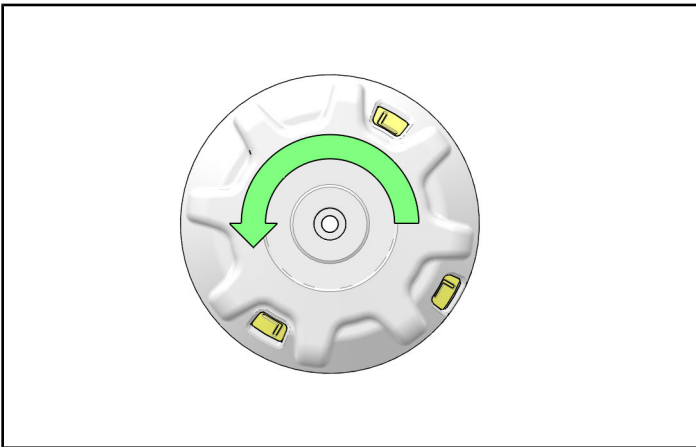

3. HIGH: Used to rapidly recover the UNLOADED rope.

Relieve all tension from the rope, then rotate gear select knob clockwise until "H" is visible in the shift knob cutout window.

If difficulty is encountered while shifting into HIGH, pull the winch rope slightly by hand to help align the gears.

IMPORTANT

High gear is ONLY used for rapid recovery of the UNLOADED winch rope. It is NOT intended for rope retraction while under load. Using high gear while under load will result in reduced winch life.

NOTE

The recovery speed in HIGH gear is approximately 5X the recovery speed in LOW gear. As a result, using this feature will significantly reduce the time needed to recover the rope after use.

Polaris recommends always returning gear selector to LOW after rapid recovery to prevent inadvertent future operation in HIGH gear.

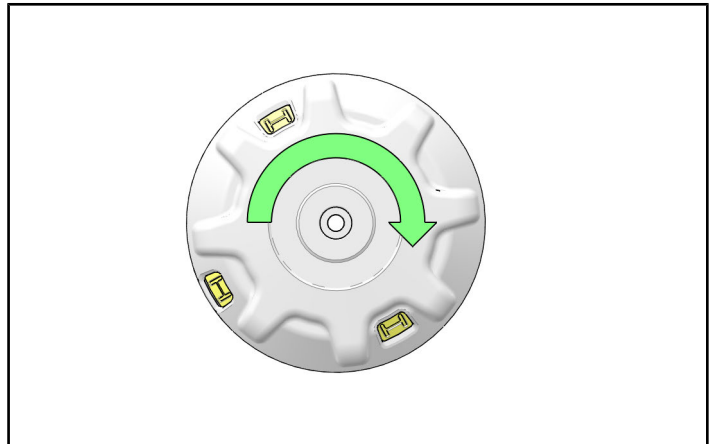

TROUBLESHOOTING

SYMPTOM	POSSIBLE CAUSES	RECOMMENDED SOLUTION
Dead vehicle battery	Incorrect, damaged, or corroded electrical connections	Verify all winch electrical connections are per instruction manual and free of damage and/or corrosion.
Winch will not operate	Contactors not receiving power	Turn vehicle key on.
	Wireless remote not powered on	Turn wireless remote on.
	Incorrect, damaged, or corroded electrical connections	Verify all winch electrical connections are per instruction manual and free of damage and/or corrosion.
	Keyed power circuit (orange wires) not properly powered	Check 10A accessory circuit fuse for continuity; replace as required.
Winch operates in one direction only	Autostop fairlead not properly connected	If winch operates only outward then ensure magnetic stop (black rubber puck) is not touching autostop fairlead. If winch operates inward even when magnetic stop is touching fairlead then verify all winch electrical connections are per instruction manual and free of damage and/or corrosion.
Winch makes noise but rope does not move	Contactors powered, but not winch	If clicking sound is heard when winch control button is depressed, but winch motor is silent, then verify electrical connections between winch and contactors are free of damage and/or corrosion. If winch makes noise but does not move, verify winch is in gear. If winch is in gear, but winch still does not move, have a dealer inspect the winch.
	Winch not in proper gear	Rotate gear knob fully into L or H, then recheck.
Winch operates too slowly	Winch is improperly loaded	Verify rope is not binding on spool or fairlead. IMPORTANT High gear is ONLY used for rapid recovery of the UNLOADED winch rope. It is NOT intended for rope retraction while under load. Using high gear while under load will result in reduced winch life.
	Winch not in proper gear	Rotate gear knob fully into L or H, then recheck. NOTE Winch is designed to operate slowly in low gear.
Winch will not change gears	Rope is under load	Changing gears while under load is intentionally difficult to prevent accidental operation, which could lead to personal injury or winch failure. Ensure rope is under no tension, and rope is not binding on spool or fairlead. Briefly operate winch, then attempt to shift again.

FEEDBACK FORM

A feedback form has been created for the installer to provide any comments, questions or concerns about the installation instructions. The form is viewable on mobile devices by scanning the QR code or by clicking [HERE](#) if viewing on a PC.

