

RZR WINCH KIT

KIT P/N 2878787; 2879334

Application

All RZR Models except RZR XP

Before you begin, read these instructions twice and check to be sure all parts and tools are accounted for. Please retain these installation instructions for future reference and parts ordering information.

This Kit Includes:

<u>Qty</u>	<u>Part Description</u>	<u>Part Number</u>
1	Weld-Winch Mount RH	1018435
1	Weld-Winch Mount LH	1018436
1	Weld-Fairlead Mount	1018437
1	Winch-POLARIS, 3.5 BT	2204688
1	Hook-Latch, Winch	2411836
1	Roller-Fairlead, Winch	2411848
1	Rope-Winch, Synthetic	2878888 (2878787)
1	Cable-Winch, Steel	2878890 (2879334)
1	Contacto-r-w/Cover	4013465
1	Remote-Switch, Winch	4013466
1	Socket-Winch	4013467
1	Cable-Winch, Yellow 6 GA, 480mm	4013468-480
1	Cable-Winch, Blue 6 GA, 400mm	4013469-400
1	Cable-Power, Winch, Black 6 GA, 1960mm	4013470-1960
1	Cable-Power, Winch, Red 6 GA, 1760mm	4013471-1760
1	KIT-Winch Hardware, RZR	2878896

<u>Qty</u>	<u>Part Description</u>	
4	1/4"-20 X 1" Capscrew GR5	
4	1/4" Flat Washer	
4	1/4"-20 Lock Nut	
4	M8 X 20mm Capscrew 8.8	
4	M8 Lock Washer	
4	M8 Flat Washer	
10	3/8"-16 X 0.75" Capscrew GR5	
10	3/8 Lock Washer	
6	3/8" Hex Nut	
2	#10-24 X0.75" Machine Screw GR5	
2	#10-24 Hex Nut	
2	#10 Lock Washer	
1	Winching Guide	9923644
1	Instructions	9923640
	Internal Cam Service Kit (Includes internal cam for freespool handle to connect winch to a replaceable handle, purchase handle separately)	2205497
	Service Handle (Includes freespool handle and screw)	2205265

Tools Required:

Metric Socket Set	Metric Open End/Box End Wrench Set
T-20 & T-27 Torx	Phillips Screwdriver
	1 1/16" Hole Saw or Drill

APPROXIMATE INSTALLATION TIME: 60 minutes

IMPORTANT: Your Polaris RZR winch is exclusively designed for your vehicle. Please read the installation instructions thoroughly before beginning. Installation is easier if the vehicle is clean and free of debris.

IMPORTANT: For your safety, and to ensure a satisfactory installation, perform all installation steps correctly in the sequence as shown on the attached instructions.

INSTALLATION PREPARATION

1. Remove the driver seat and disconnect the positive (red) wire and the negative (black) wire from the battery by using a 10 mm wrench. Figure 1.



2. Remove the winch cover panel in the front bumper by removing the four T-25 screws. Figure 2.



WINCH INSTALLATION

1. Install the two winch mounting brackets through the front opening. Line up bracket holes with mounting holes in frame. Install four 3/8" bolts, two in the front two in the rear. Torque to 18 ft. lbs.(24.4 Nm). Figure 3.

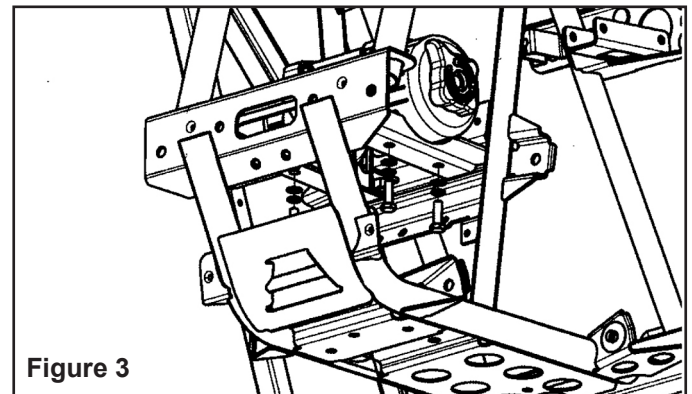

2. Install the fairlead bracket to the chassis with four 3/8" capscrews, four lock washers and four nuts. Figure 4.

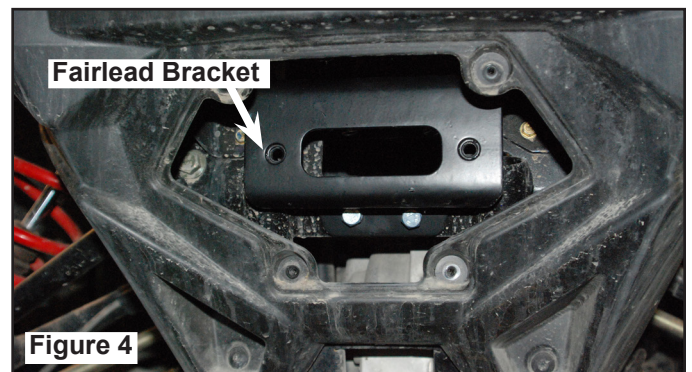

3. Install the fairlead to the fairlead bracket with two 3/8" capscrews and two each flat washers and lock washers. Figure 5.

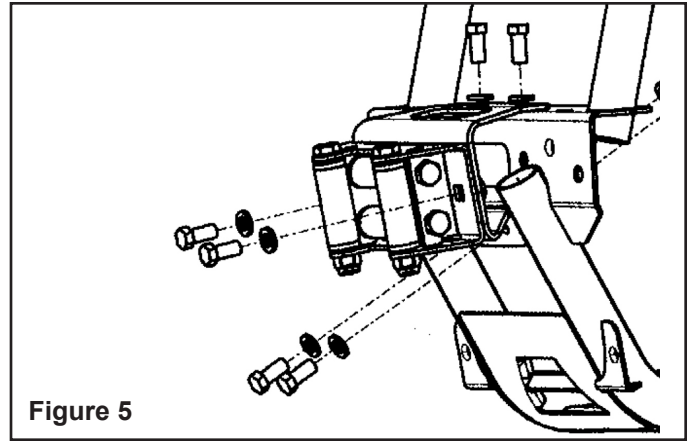

4. Install the winch to the previously installed winch mount brackets by using four M8 capscrews, four lock washers and four flat washers. Torque to 12 ft. lbs. (16.2 Nm). Figure 6.

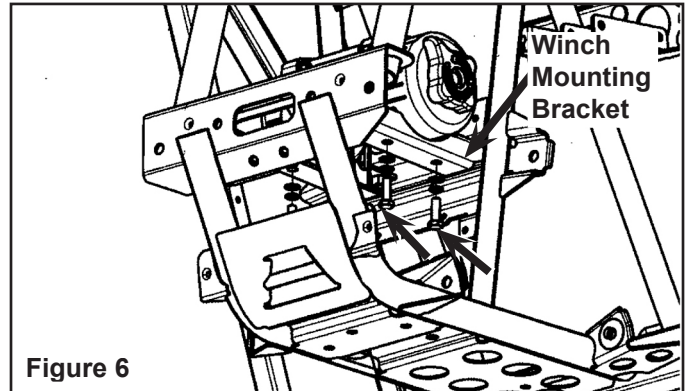

5. Route the synthetic or steel cable through the fairlead and install the hook with cotter pin. Figure 7.



CONTACTOR INSTALLATION

1. Remove hood by the quarter turn fasteners.
2. Remove toolbox by removing seven torx screws. Save for re-installation.
3. Install the contactor to the firewall on the inside right fender well. Locate and remove four push-dart clips in the contactor mounting holes in the firewall.

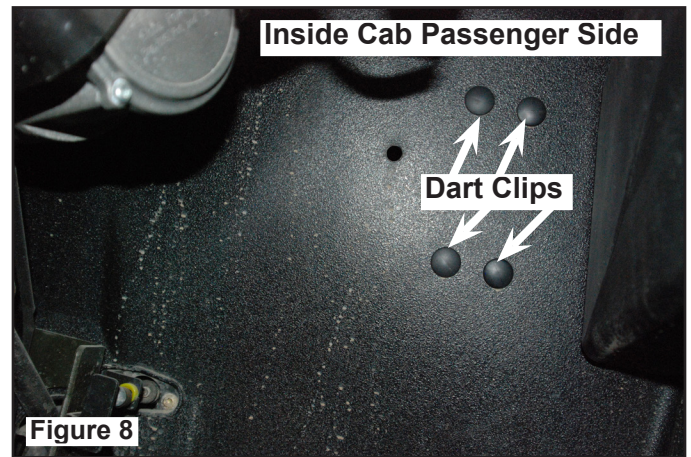

4. Install the contactor with four 1/4"-20 capscrews, washers and nuts.



REMOTE SOCKET INSTALLATION

⚠ WARNING	
	TO PREVENT SERIOUS INJURY OR DEATH FROM EXPLOSION: <ul style="list-style-type: none">• Do not drill into gas tank.• Verify the area is clear behind the mounting location before drilling.

1. Determine the mounting location for the remote socket (suggested location is to the left of the steering wheel on the dash). Confirm that the wiring will reach the contactor.
2. Place template from Page 7 on vehicle with tape and drill the three mounting holes. Attach the socket to the vehicle by using two M5 screws, two washers and two nuts.
3. With the remote socket mounted, route the black and green wires to the contactor and connect this connector to the contactor. Route the red wire under the dash and connect it to the accessory powered terminal on the buss bar located in the hood.

WIRING INSTALLATION

1. Place the two terminal rubber boots on the blue and yellow wires before securing them to the motor.
2. Attach the yellow and blue wires to the corresponding colored motor terminals on the winch. Route the wires through the contactor cover and connecting them to the corresponding colored contactor posts.
3. Route the red and black wires through the contactor cover, attach the red wire to the red post on the contactor and the positive (+) terminal of the battery. Attach the black wire to the black post on the contactor and the negative (-) terminal of the battery.
4. Secure all loose wires with zip ties and secure contactor cover to the contactor.

FINAL INSTALLATION

1. Confirm that all wiring is correct.
2. All loose wires need to be wrapped tight, and secured away from moving parts and heat sources.
3. Confirm that there are no exposed wires or terminals.
4. With the vehicle key in the ON position, check winch for proper operation.
5. Reinstall toolbox and hood.
6. Retighten all hardware after 30 minutes of riding.

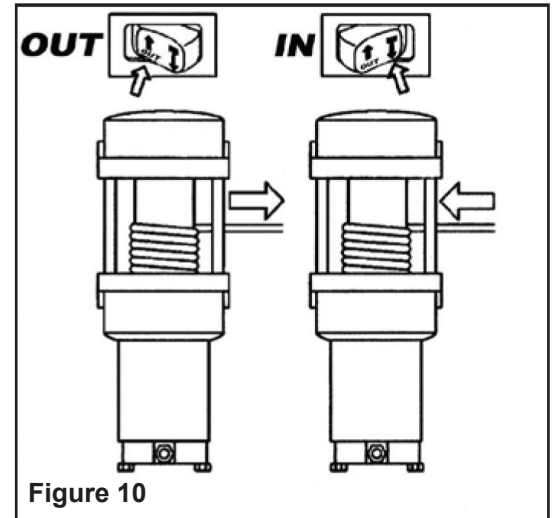

THIS PAGE INTENTIONALLY LEFT BLANK

Cut On Dotted Line

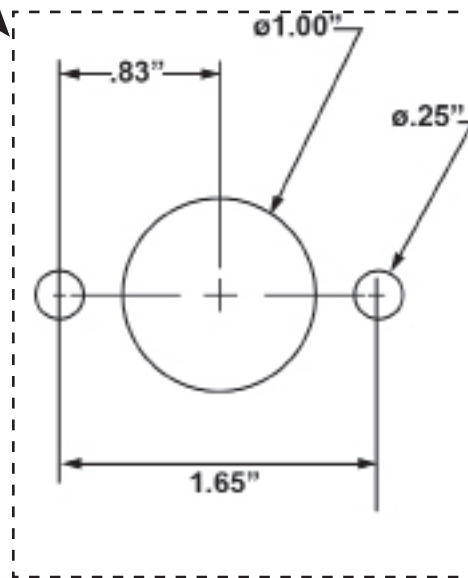

Measure the template after printing to be sure the template has printed correctly