

PERFORMANCE STEERING WHEEL KIT



SLINGSHOT

P/N 2882335

APPLICATION

All 2014 and newer Slingshot® models

BEFORE YOU BEGIN

Read these instructions and check to be sure all parts and tools are accounted for. Please retain these installation instructions for future reference and parts ordering information.

DISCLAIMER ACCESSORY WEIGHT

When adding accessories, equipment, passengers and luggage to your vehicle, do not exceed the total weight capacity of the vehicle or of the front or rear axle (GVWR or GAWR as indicated on the Safety Compliance Certification label). Ask an authorized dealer for specific weight information if you need assistance. It is the owner's responsibility to use the Polaris Slingshot Accessories website as a tool for limiting the amount of accessories, based on maximum allowable vehicle weight requirements. It may be a violation of the Clean Air Act or the NHTSA regulations to disregard these requirements. For a complete listing of the accessories that are available for your vehicle, please contact your authorized dealer or visit the online store web site: Web Address (United States): <http://www.polaris.com/en-us/slingshot/shop/accessories>.

KIT CONTENTS

This Kit includes:

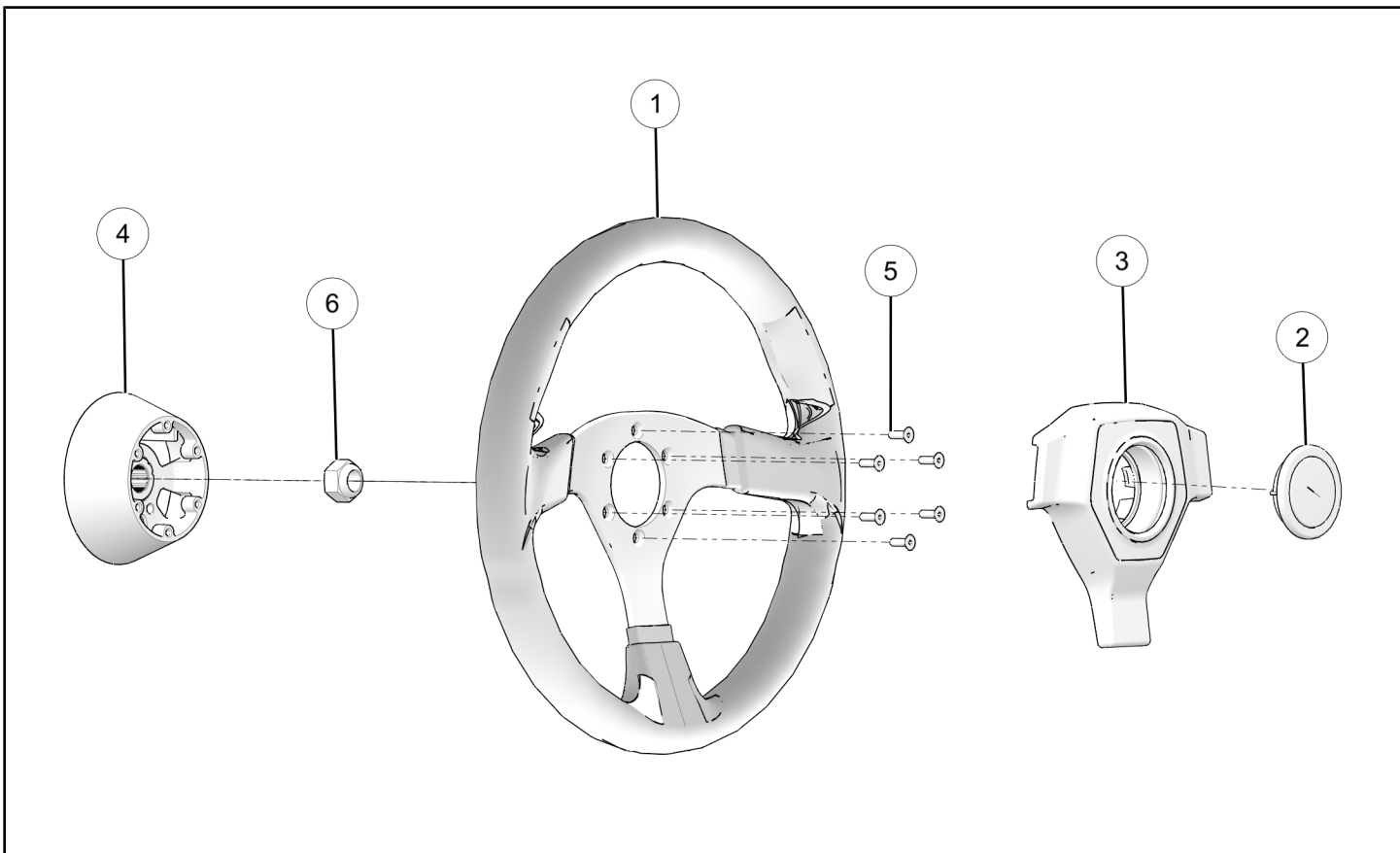

REF	QTY	PART DESCRIPTION	PART NUMBER
1	1	Steering Wheel	1824520
2	1	Horn Button Assembly	2413648

REF	QTY	PART DESCRIPTION	PART NUMBER
3	1	Steering Wheel Pad	5416619
4	1	Hub Adaptor, Steering Wheel	5141291
5	6	Screw, Flat Head, 1032 X 5/8	7520731
6	1	Nut, Hex, M16 X 2	7547506
	1	Instructions	9927605

TOOLS REQUIRED

- Safety Glasses
- Socket Set, Metric
- Socket Set, Torx® Bit
- Torque Wrench
- **Special Service Tool:**
Steering Wheel Puller PN PS-48041–A

CONSUMABLES REQUIRED

- Wipe, Isopropyl Alcohol (IPA)
- Gloves, Chemical Resistant

IMPORTANT

Your Performance Steering Wheel Kit is exclusively designed for your vehicle. Please read the installation instructions thoroughly before beginning. Installation is easier if the vehicle is clean and free of debris. For your safety, and to ensure a satisfactory installation, perform all installation steps correctly in the sequence shown.

ASSEMBLY TIME

Approximately 30 minutes

INSTALLATION INSTRUCTIONS

1. Ensure steering wheel and front wheels are aligned straight.
2. Shift vehicle transmission to NEUTRAL. Turn Key to OFF position and remove from vehicle.
2. Remove and discard horn pad (B) from steering wheel (C) by prying up from bottom of horn pad (B) and working upwards until all three arms of horn pad (B) are removed.

Apply parking brake.

Disconnect two horn wire connectors connecting horn assembly to horn pad (B).

STOCK STEERING WHEEL REMOVAL

1. Remove and discard Slingshot® emblem (A) from horn pad (B) by carefully prying emblem off.

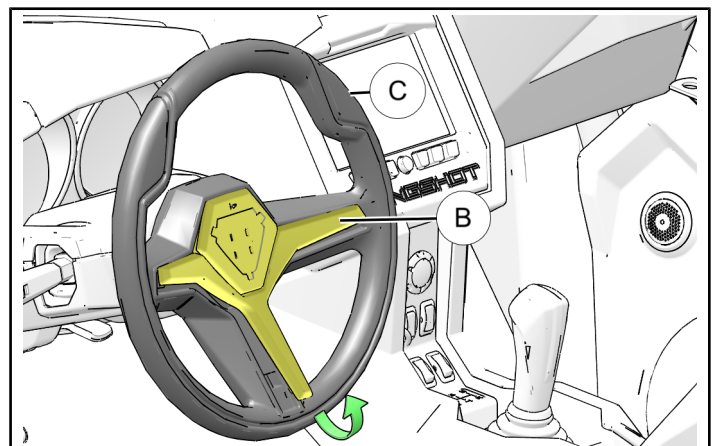
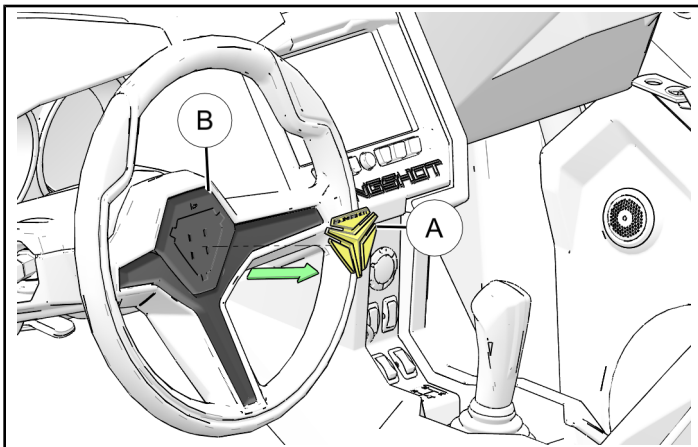

- Remove and discard nut **D** securing steering wheel **C** to steering wheel shaft **E**.

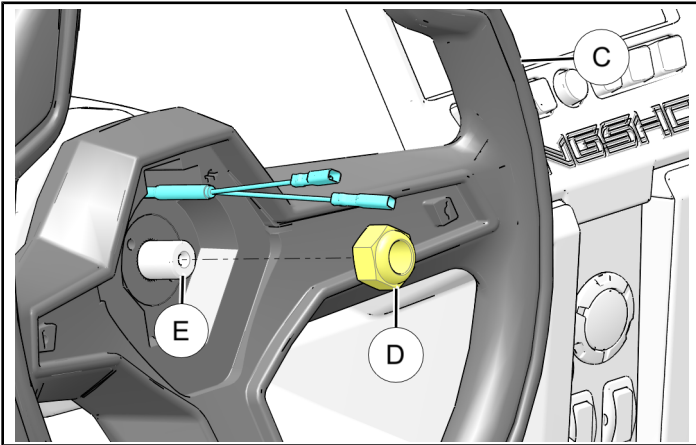

- Mark top center of steering wheel shaft to aid in Performance Steering Wheel alignment.

Remove steering wheel **C** from steering wheel shaft **E** with steering wheel puller.

CAUTION

Striking steering wheel or steering shaft to assist in steering wheel removal is **strongly** discouraged. Striking steering wheel or steering shaft can result in permanently damaging the EPS unit or power steering.

TIP

Use steering wheel puller PN PS-48041-A.

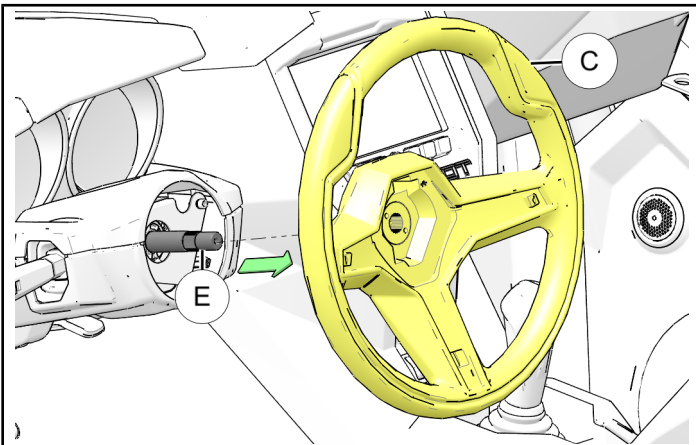

PERFORMANCE STEERING WHEEL INSTALLATION

- Ensure horn wire opening in hub adapter **4** is properly aligned by aligning top center hole on steering wheel **1** with corresponding top left hole on hub adapter **4** as shown. Secure steering wheel **1** to hub adapter **4** with six fasteners **5**.

Torque six fasteners **5** to specification.

TORQUE

72 in. lbs. (8 Nm)

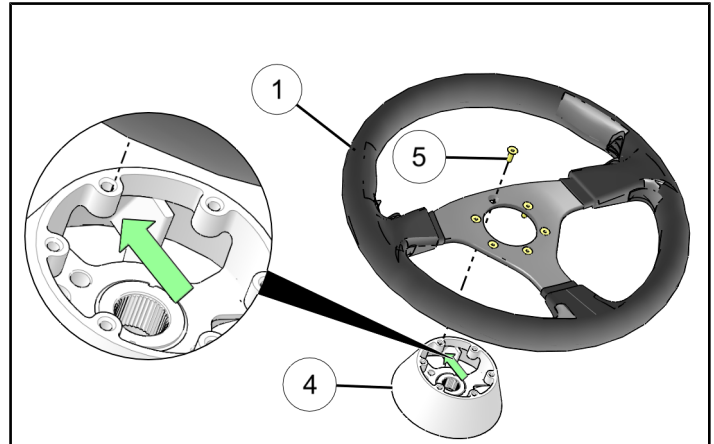

- Place horn wires **F** through opening of hub adapter while aligning steering wheel assembly **1** onto steering wheel shaft **E**. Left and right steering wheel spokes should be horizontal while third spoke should be directed downward.

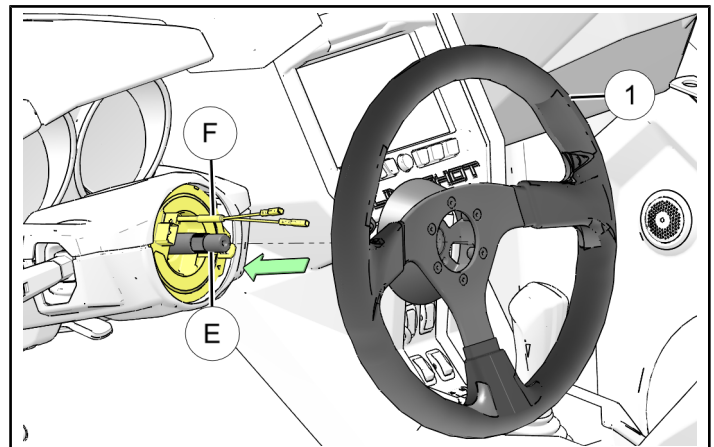

3. Align steering wheel assembly ① with mark made in **Step 4 of Stock Steering Wheel Removal**. Fasten hub adapter ④ of steering wheel assembly ① to steering wheel shaft ⑤ with nut ⑥.

Counter hold steering wheel while torquing nut ⑥ to specification.

TORQUE

35 ft. lbs. (47 Nm)

NOTE

One full thread of steering wheel shaft should be extended past nut after torquing.

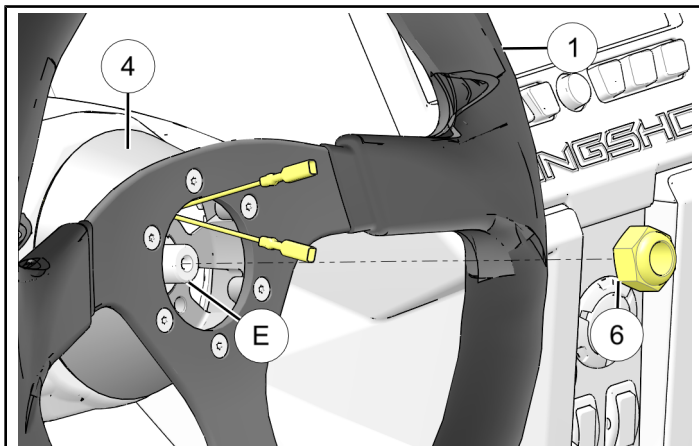

4. Clean steering wheel spoke surface with solvent wipe prior to installing horn pad.

⚠ WARNING

Isopropyl alcohol is hazardous to your health. See isopropyl alcohol packaging for proper handling instructions, including recommended personal protective equipment such as goggles and chemical resistant gloves.

- a. Peel off back of double sided tape ⑥ from back of horn pad ③.

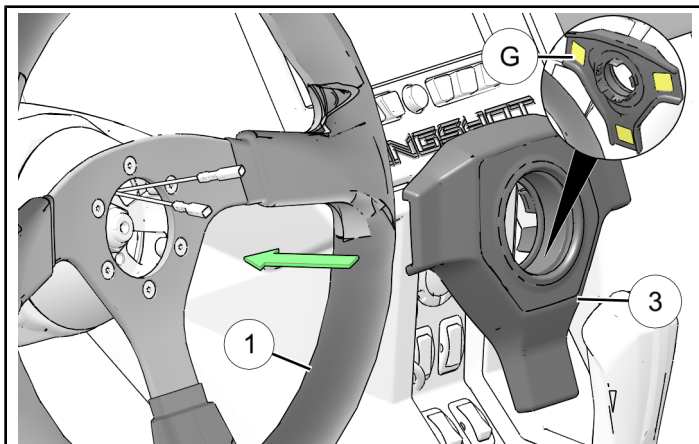

- b. Align horn pad ③ on steering wheel ① and firmly press down.

Ensure horn wires are not pinched between horn pad and steering wheel.

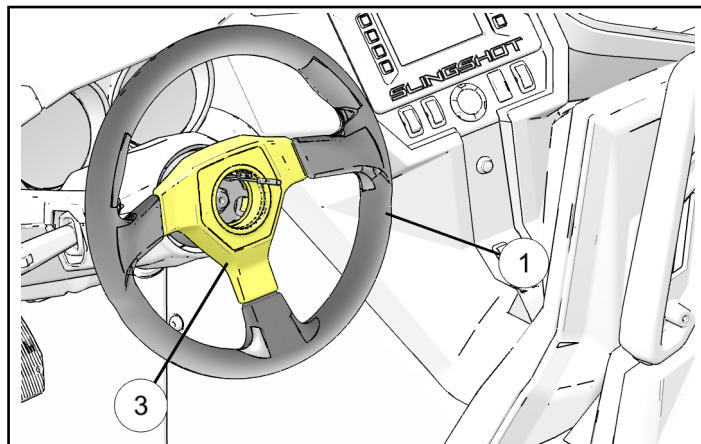

5. Locate horn wires in center of steering wheel assembly ①. Connect horn wire tabs to horn button and install horn button ② by firmly pushing around its edges.

NOTE

If steering wheel spokes do not align properly but wheels are straight, a wheel alignment is needed. Refer to service manual for wheel alignment procedures.

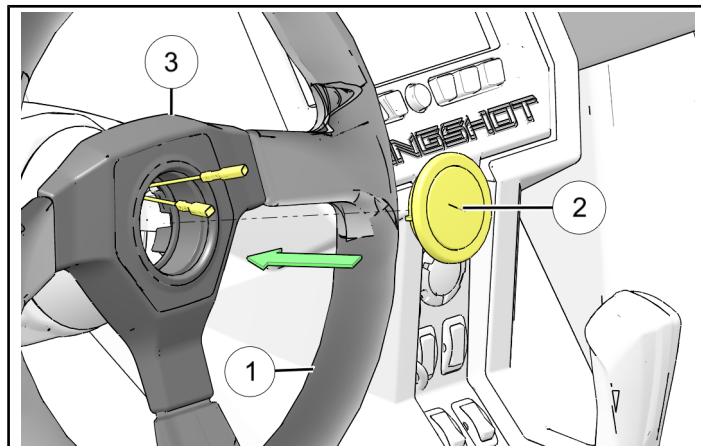

FEEDBACK FORM

A feedback form has been created for the installer to provide any comments, questions or concerns about the installation instructions. The form is viewable on mobile devices by scanning the QR code or by clicking [HERE](#) if viewing on a PC.

