

# 850 TETHER SWITCH KIT



**P/N 2883823**

## APPLICATION

Verify accessory fitment at [Polaris.com](http://Polaris.com).

## BEFORE YOU BEGIN

Read these instructions and check to be sure all parts and tools are accounted for. Please retain these installation instructions for future reference and parts ordering information.

## KIT CONTENTS

This Kit includes:

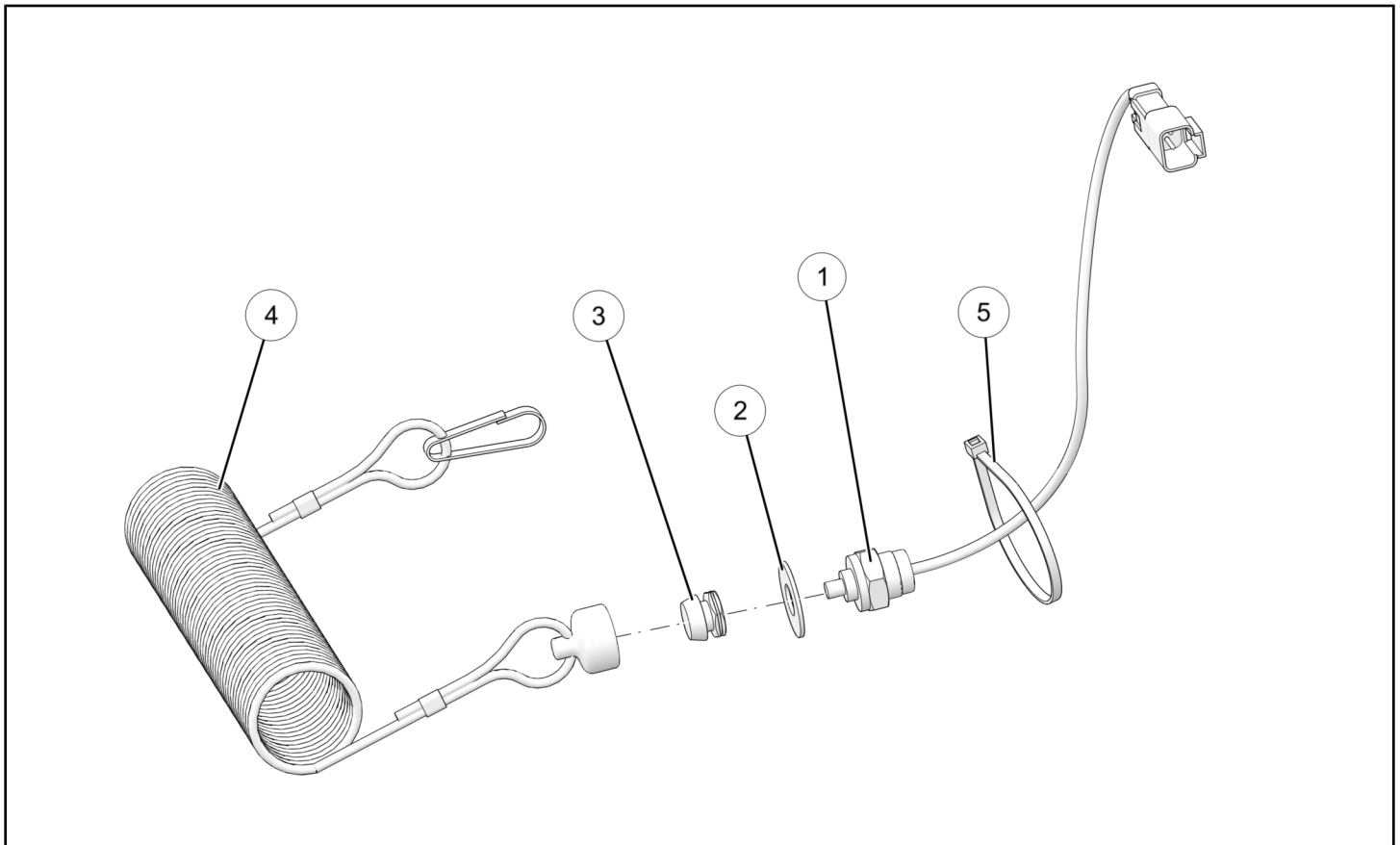

REF	QTY	PART DESCRIPTION	PART NUMBER
1	1	Tether Switch (Includes Items 3 & 4)	4018197
2	1	Flat Washer	7555817
3	1	Threaded Cap	-
4	1	Tether Cord	-
5	1	Cable Tie	7080138
	1	Instructions	9928801

## TOOLS REQUIRED

- Safety Glasses
- Cutting Tool
- Drill
- Hole Saw: 1/2" (13 mm)
- Pliers, Side Cutting
- Wrench Set, Metric
- Socket Set, Torx® Bit

## CONSUMABLES REQUIRED

- None

## IMPORTANT

Your 850 Tether Switch Kit is exclusively designed for your vehicle. Please read the installation instructions thoroughly before beginning. Installation is easier if the vehicle is clean and free of debris. For your safety, and to ensure a satisfactory installation, perform all installation steps correctly in the sequence shown.

## ASSEMBLY TIME

Approximately 30 minutes

### NOTE

Additional time may be required for optional steps, or to accommodate other installed accessories.

## INSTALLATION INSTRUCTIONS

### 1. Remove Hood and Side Panels.

- Remove side panel **C** by rotating the two side panel latches **A** 90° in a clockwise direction to unlatch. Then pull outward on the rubber strap **B** on the front lower portion of the panel as indicated to disengage the strap from the molded strap hook on the panel. Pull out on upper portion of side panel to remove. Repeat for opposite side.

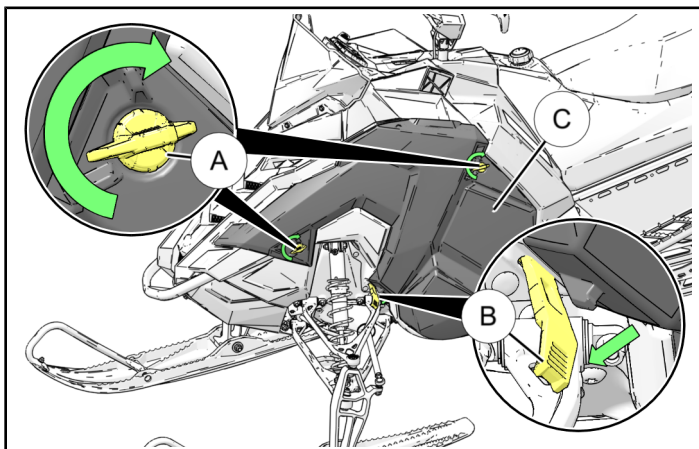

- Next, remove the hood assembly **D** by first rotating the two hood latch fasteners **E** 180° counterclockwise.

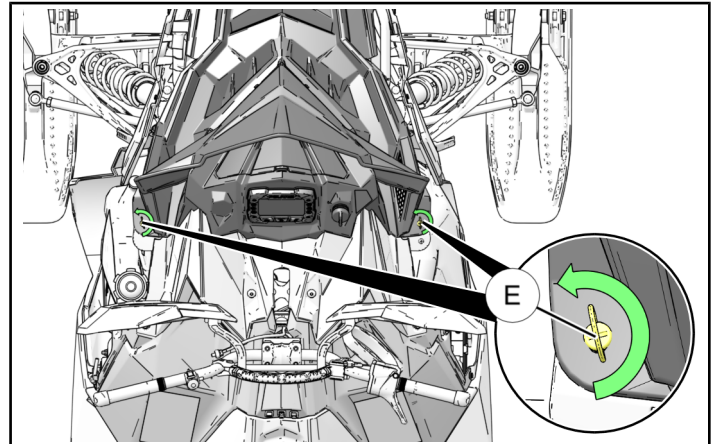

Slightly lift the rear of the hood assembly to gain access to the main hood harness connector (F) and disconnect from main chassis harness connector (G). Cut the cable tie (H) securing the hood harness to the chassis and remove hood.

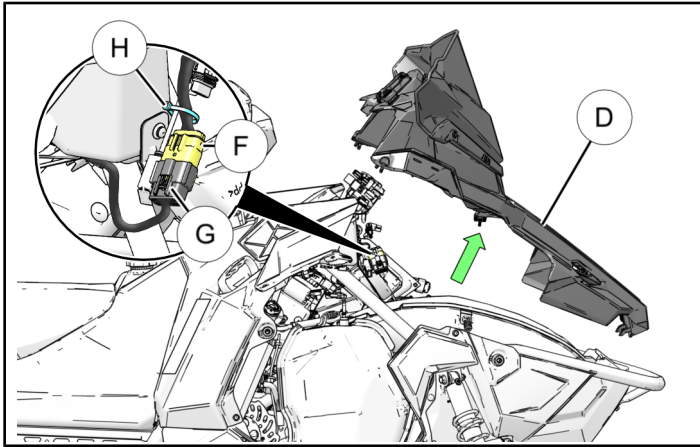

c. Remove the two screws (F) that attach the upper intake plenum (H) to the over-structure along with the two dart clips (G) as shown. Once complete, remove upper intake plenum (H).

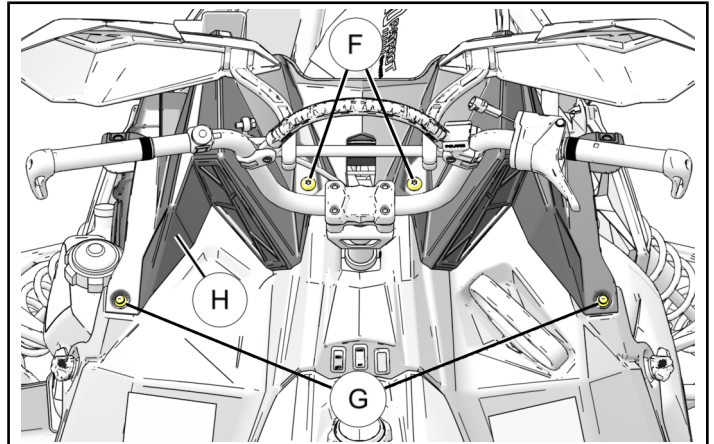

## 2. Remove Upper Intake Plenum.

a. To do so, first remove the two dart clips (B) and cable tie (C) that fasten the intermediate intake tube (A) to the upper intake plenum..

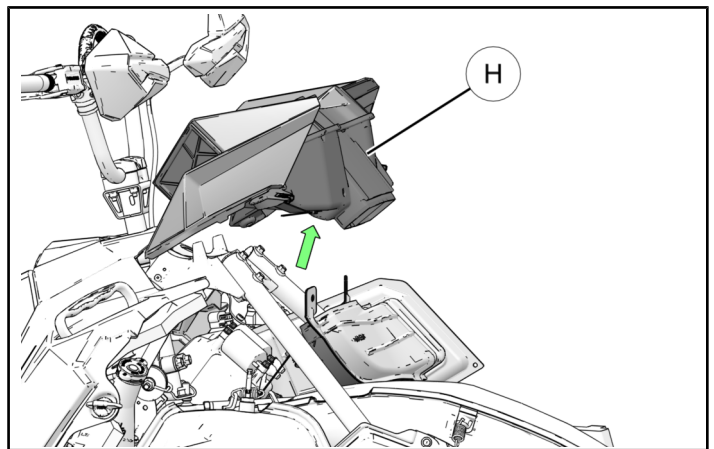
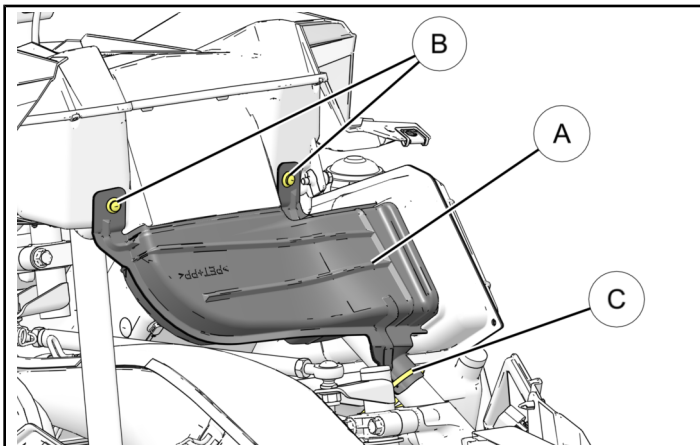

b. Next, unplug the two electrical connectors (D) from the ECU (E).

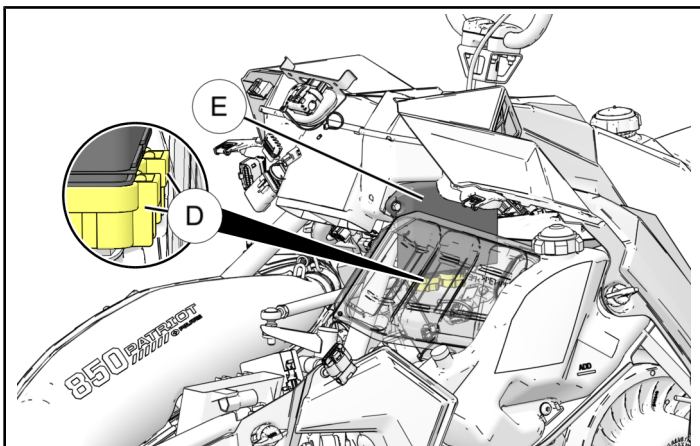

### 3. Remove Console.

- a. Remove two dart clips (L) on right side along with clutch tool (K) and dart clip (L) from left side.

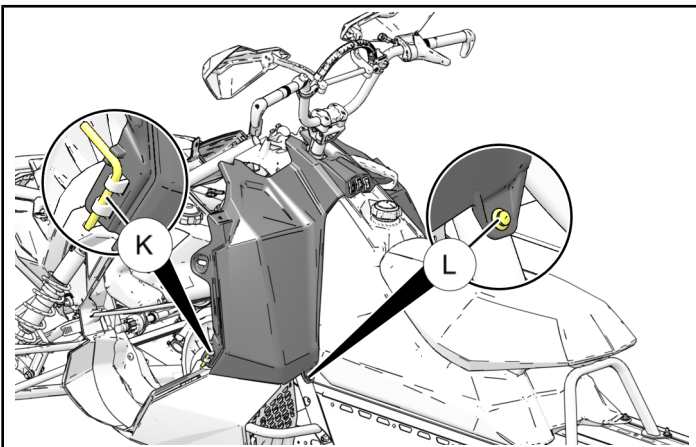
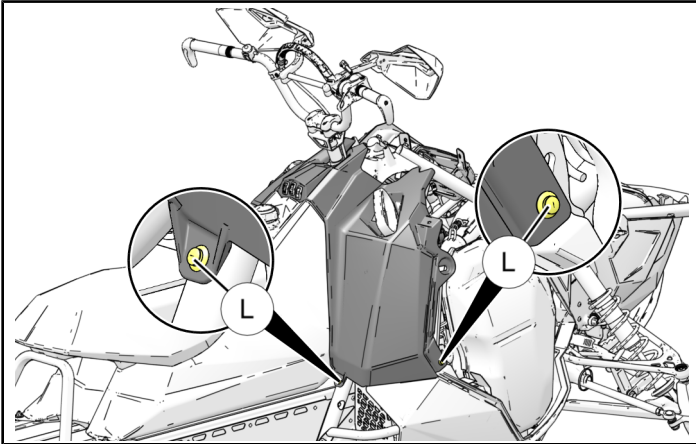

- b. Slide console (M) rearward enough to disconnect the console switch harness connector (N) from the chassis harness (P). Leave starter rope/handle still attached to the console.

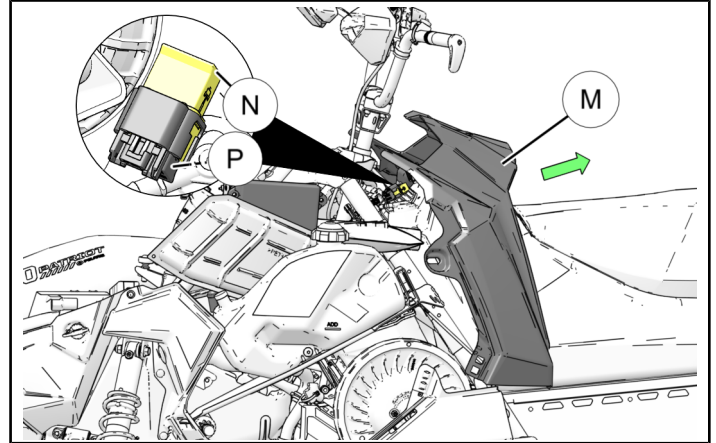

The console should now be in a position to allow you to drill the tether switch mounting hole in the following steps.

#### CAUTION

Be sure to reposition and shield ALL electrical wires, connectors and underlying components that are on the backside of the area to be drilled/cut BEFORE proceeding to the next step. Failure to comply may result in damage to the electrical system and/or underlying components.

### 4. Install Tether Assembly.

- a. A template is located on the last page of the instruction manual. Verify the REFERENCE DIMENSION is exactly 4 inches (10.16 cm).

#### IMPORTANT

If your measurement is not exactly 4 inches (10.16 cm), then reprint template pages from electronic file using print setting “**Actual Size**” (not “Fit”) to obtain proper 1:1 scale. Electronic file available from your **Authorized Polaris Dealer**.



- b. Carefully cut out and tape provided template **V** to console as shown.

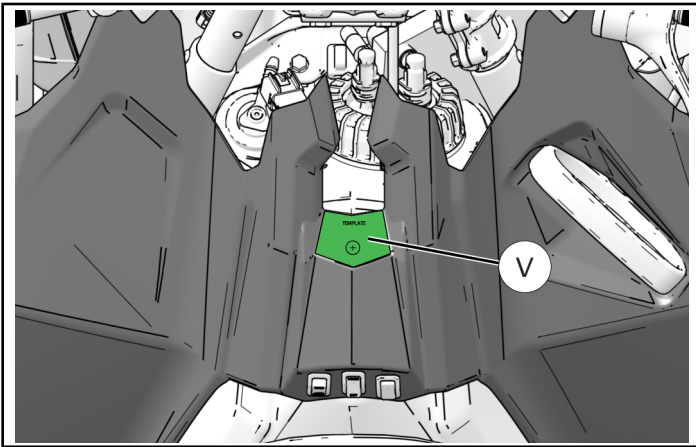

- c. Using a center punch/scribe or equivalent make a mark at the center of the hole location on the template.
- d. Using a drill and a 1/2" (13 mm) hole saw, drill the marked hole location.

- e. After drilling hole, place washer **2** onto tether cord assembly **1** and insert thru the newly drilled hole from the underside of the console **M** as shown. Once thru, secure by tightening threaded cap **3** onto tether cord. Tighten until snug.

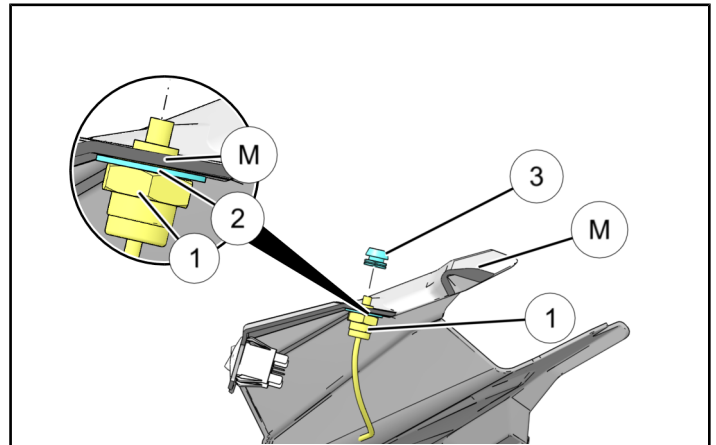

- f. Next, locate the fabric bag **R** covering the electrical connections in the area indicated. Open the bag and locate the male two pin powered accessory plug **T** that will connect to the tether switch and remove the protective cover **U** as shown.

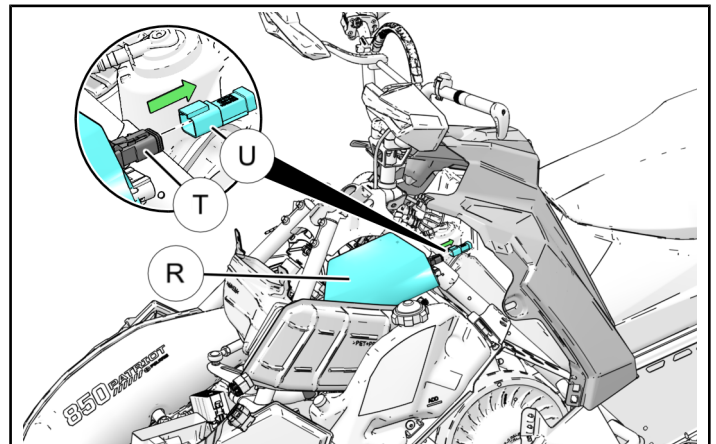

- g. Locate the female connector of the tether (S) and connect with the male end on the chassis harness (T). Once connected, close the electrical cover bag (R) over the connections.

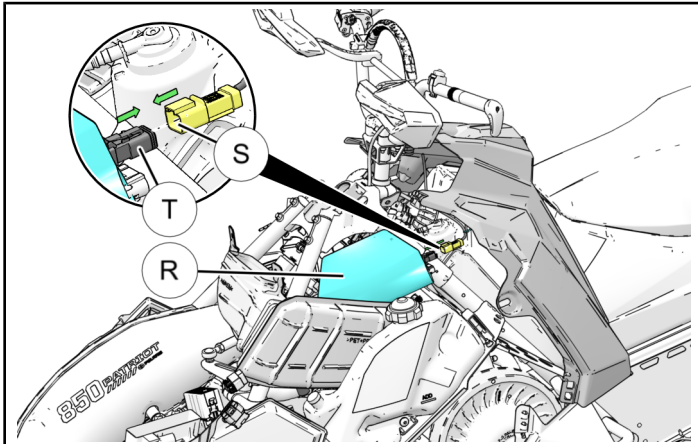

- b. Install previously removed dart clips (L) on both right and left sides along with the clutch tool (K).

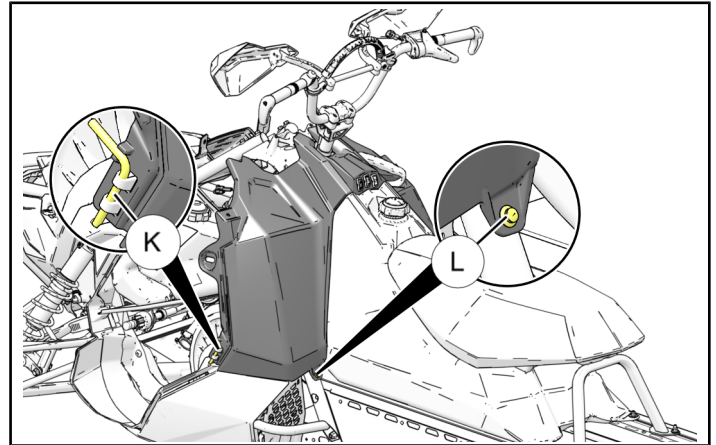

## 5. Reinstall Console.

- a. Place console (M) near its original position and reconnect the accessory switch harness connection (N) to the chassis electrical harness connection (P) as shown.

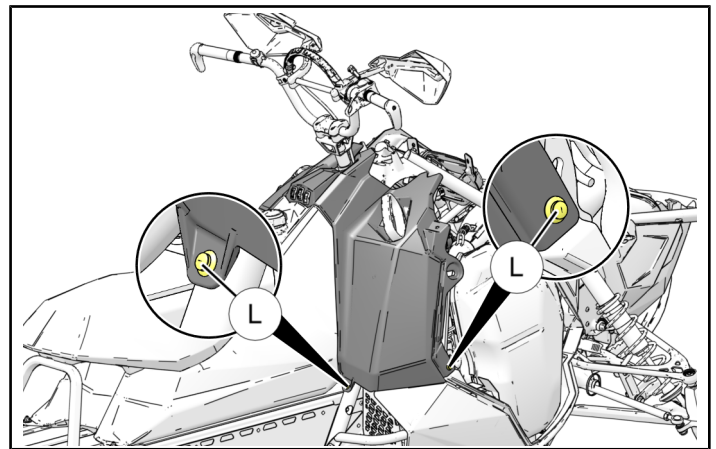
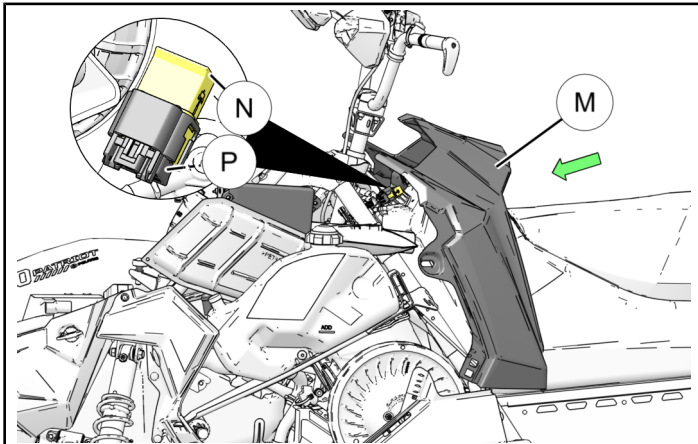

## 6. Reinstall Upper Intake Plenum.

- a. Carefully install upper intake plenum (H) back into original position. Ensure the console tabs (W) are fully engaged into the slots (X) on the underside of the intake plenum.

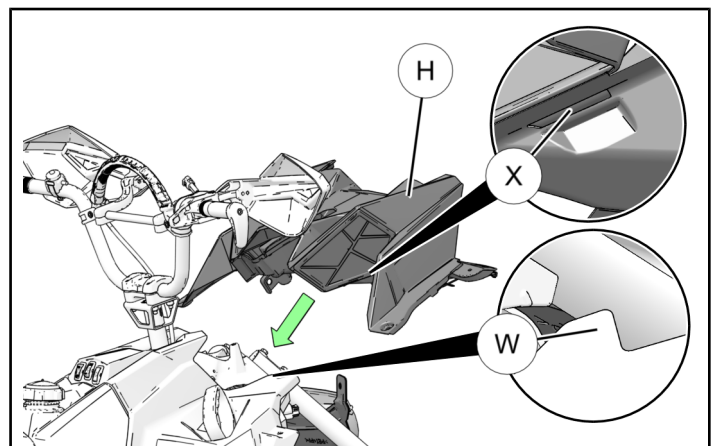

### NOTE

Careful not to damage the intake screen while installing.

- b. Install dart clips (J) and fasteners (G) that secure the intake plenum to the over-structure and torque fasteners (G) to specification provided.

### TORQUE

7 ft. lbs. (10 Nm)

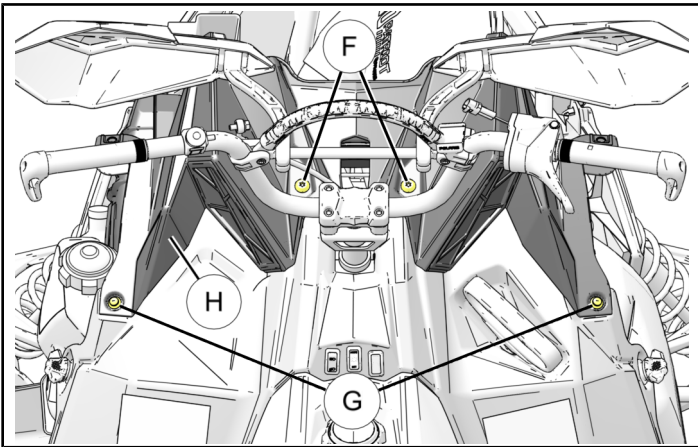

- c. Place intake tube (A) back into position and secure with previously removed dart clip fasteners (B). Replace cable tie (C) to secure lower portion of intake tube.

### IMPORTANT

Ensure the mating joint between the upper intake plenum and the intake tube is completely engaged all the way around the mating joint. Failure to do so may result in premature engine failure.

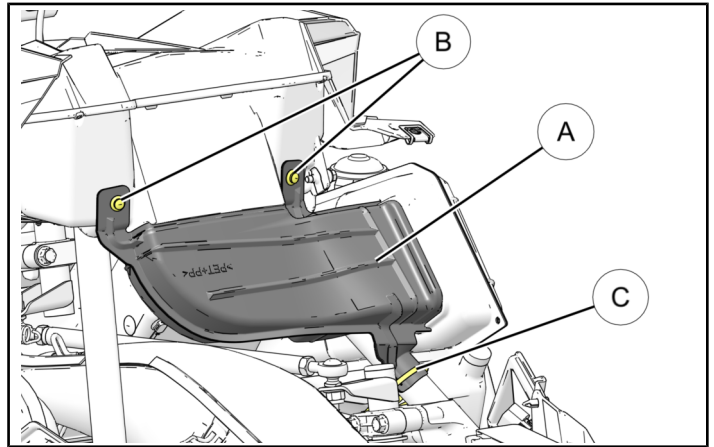

- d. Reconnect ECU.

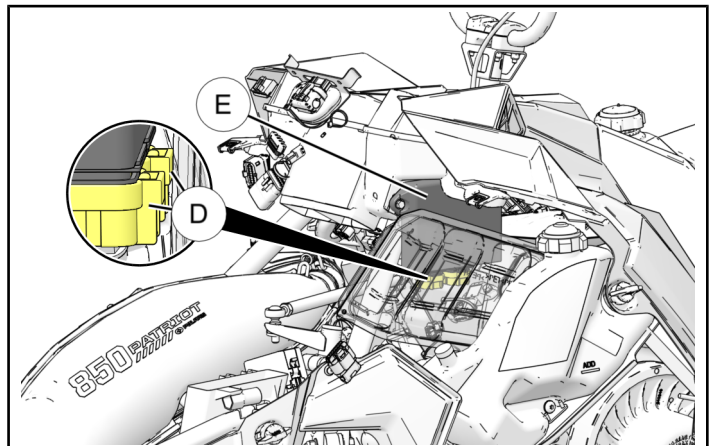



## 7. Reinstall Side Panels and Hood.

- a. Install hood being sure to connect the hood harness (F) and chassis harness (G) connection. Secure hood into position with hood latch fasteners (E).

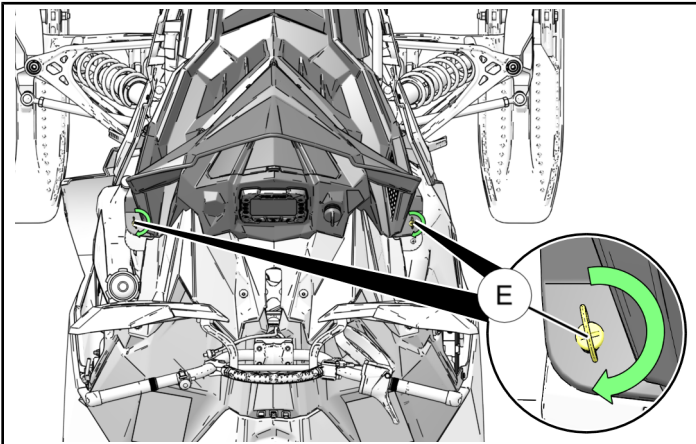
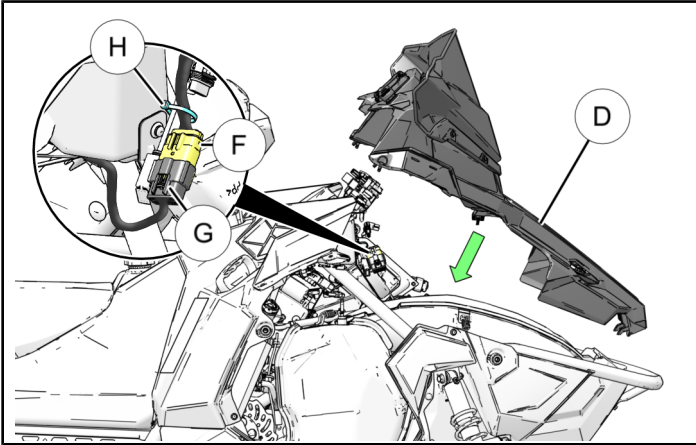

- b. After installing hood, install both side panels making sure all latches and rubber straps are fully secured.

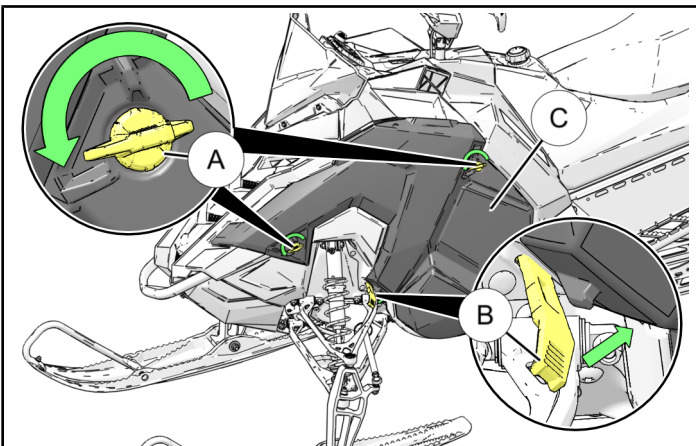

## 8. Verify Work.

- a. Check to ensure all tools are accounted for and all steps have been completed.

## 9. Verify Tether Functionality.

- a. Move vehicle outside and push tether cord onto switch until it is fully seated as shown.

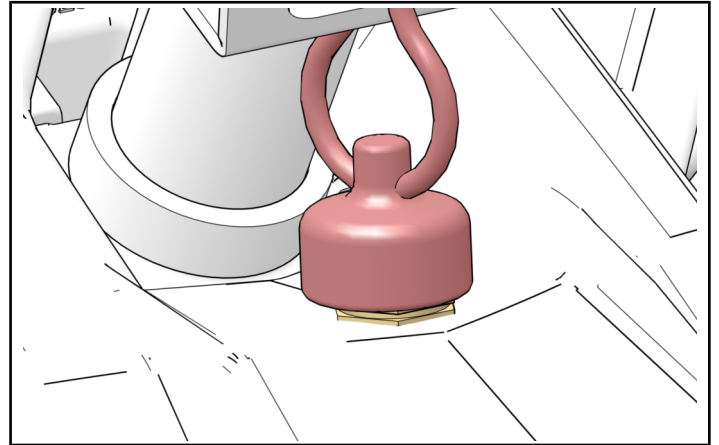

- b. Start vehicle and remove tether cord to ensure it is functioning properly. Vehicle should stop running once tether cord is removed.



## FEEDBACK FORM

A feedback form has been created for the installer to provide any comments, questions or concerns about the installation instructions. The form is viewable on mobile devices by scanning the QR code or by clicking [HERE](#) if viewing on a PC.



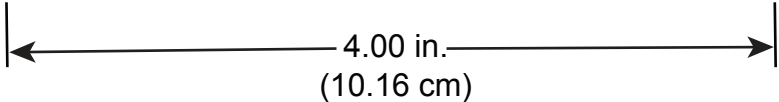
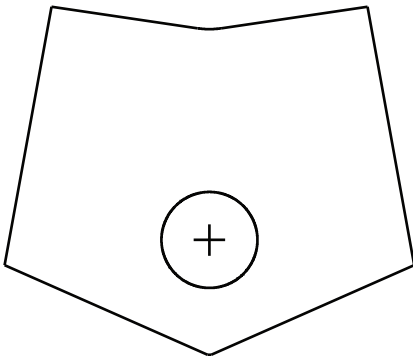

**REFERENCE DIMENSION**