

STRAIGHT HANDLEBAR KIT



P/N 2881973

APPLICATION

All straight bar applications, excluding 550 Indy and Voyageur models

BEFORE YOU BEGIN

Read these instructions and check to be sure all parts and tools are accounted for. Please retain these installation instructions for future reference and parts ordering information.

KIT CONTENTS

This Kit includes:

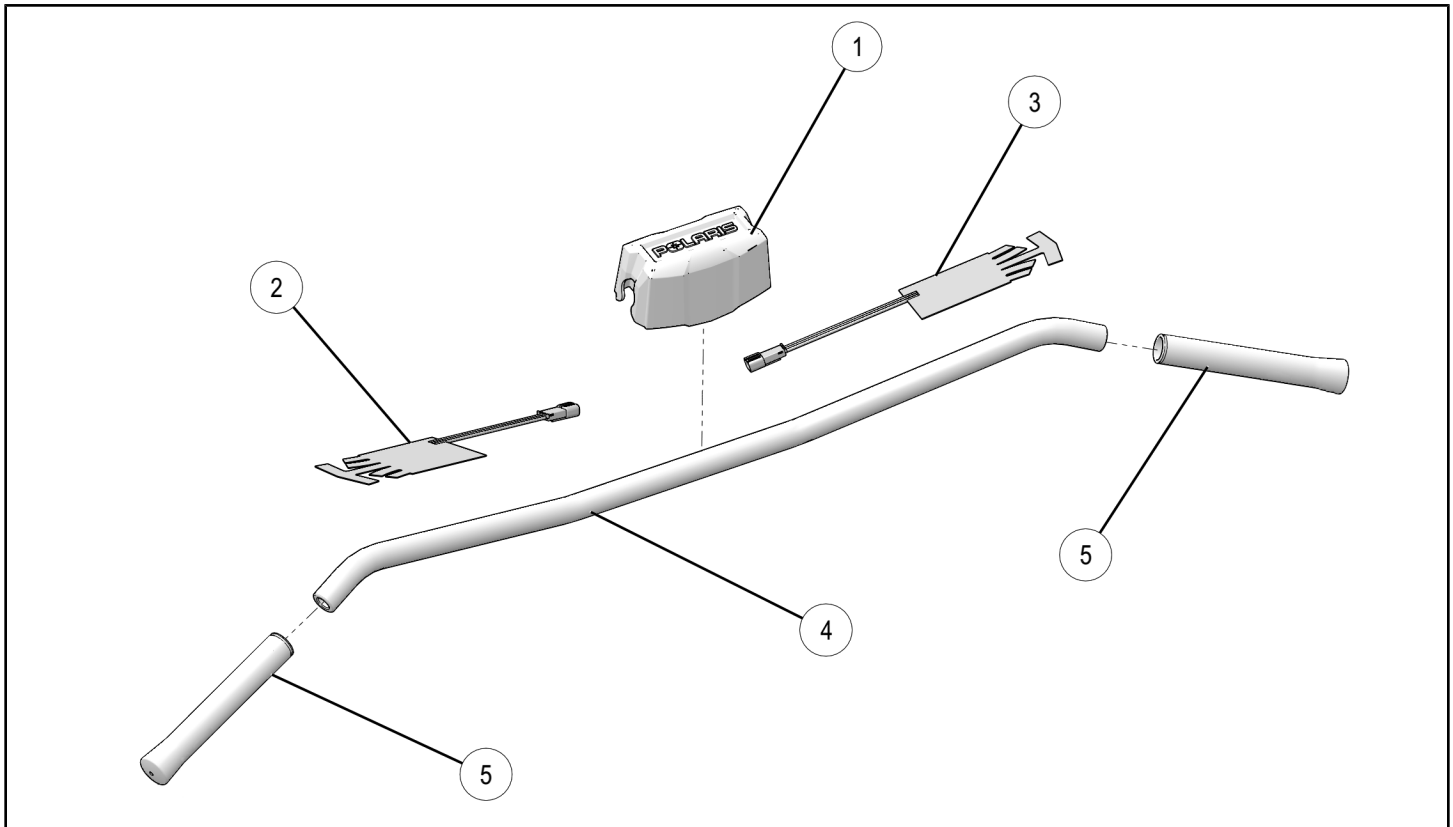

REF	QTY	PART DESCRIPTION	PART NUMBER
1	1	Cover, Handlebar Assembly	1824388
2	1	Heater Grip, LH, Low/Medium/High	2413073
3	1	Heater Grip, RH, Low/Medium/High	2413074
4	1	Handlebar, Integrated Hooks	5338964
5	2	Grip, Handlebar	5452065
	1	Instructions	9927559

TOOLS REQUIRED

- T40 Torx®
- T30 Torx®
- T20 Torx®
- 13mm Wrench
- 13mm Socket
- Torque Wrench
- Safety Glasses
- Channel Lock Pliers

IMPORTANT

Your STRAIGHT HANDLEBAR KIT is exclusively designed for your vehicle. Please read the installation instructions thoroughly before beginning. Installation is easier if the vehicle is clean and free of debris. For your safety, and to ensure a satisfactory installation, perform all installation steps correctly in the sequence shown.

ASSEMBLY TIME

Approximately 1 hr.

INSTALLATION INSTRUCTIONS

REMOVAL

1. Rotate two latches (A) at the front and rear of the panel (C) and release the strap (B) at the lower edge of the side panel.

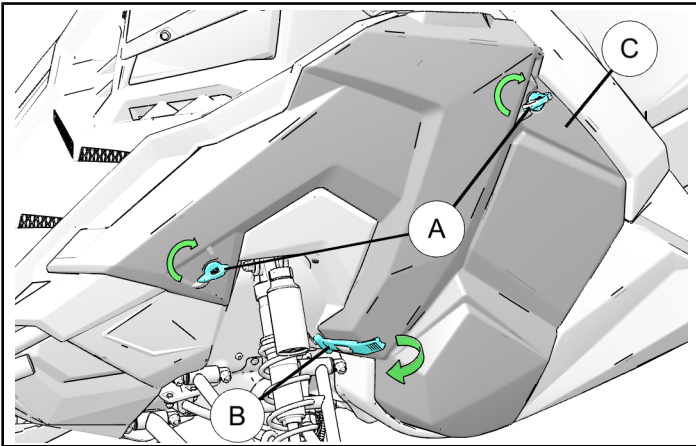

2. Open the side panel (C), then pull the panel outward to release the tabs at the bottom. Repeat the same for removing side panel on other side of vehicle.

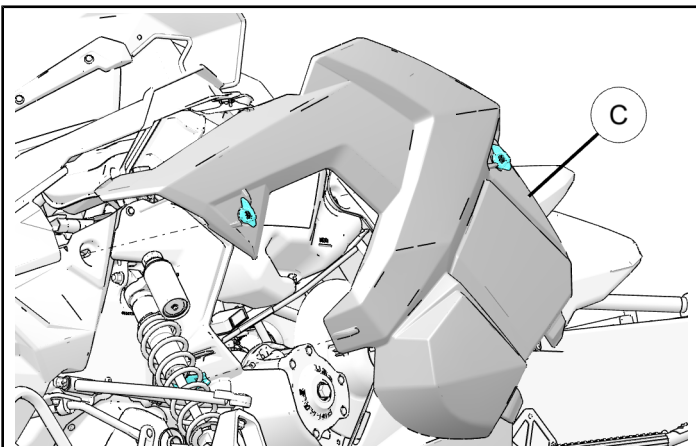

3. Rotate the 1/4 turn fasteners (D) at the rear corners of the hood (E).

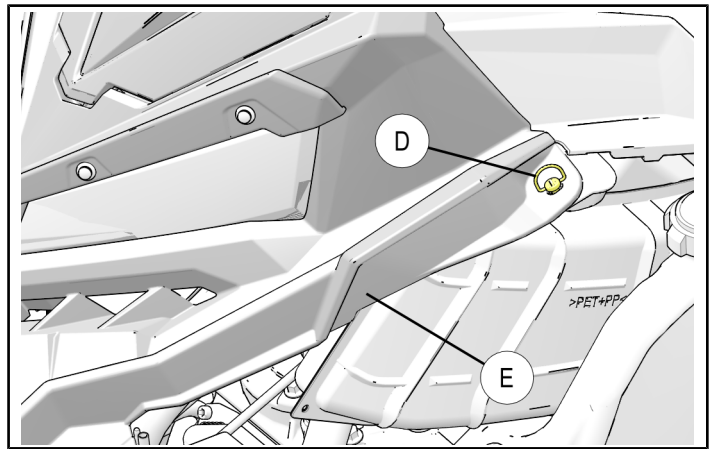

4. Disconnect the hood wire harness connector (F).

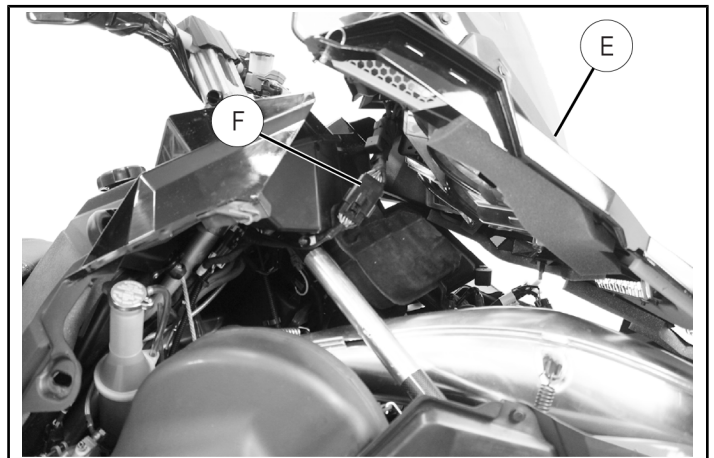

5. Remove the hood assembly (E) from the vehicle.

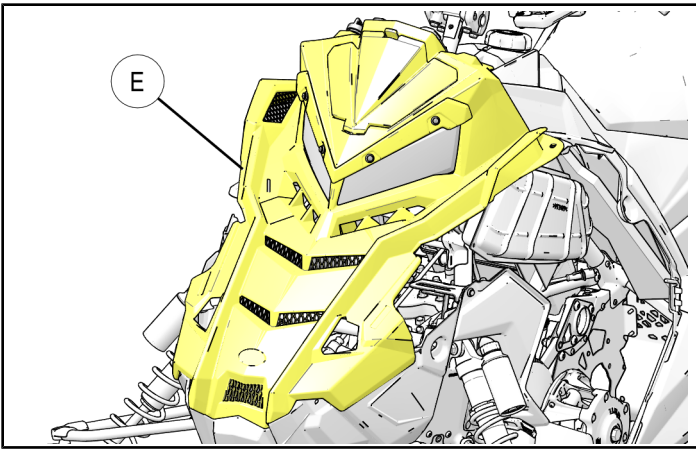

6. Cut both Panduit straps (G) that hold the wires secure to the handlebars.

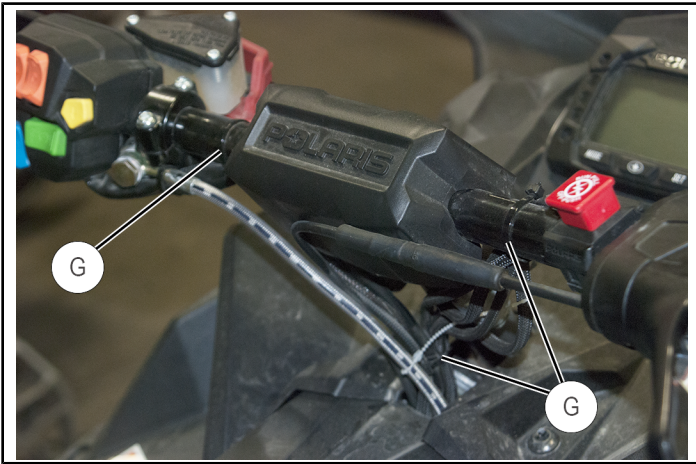

7. Remove the handlebar cover (AG).

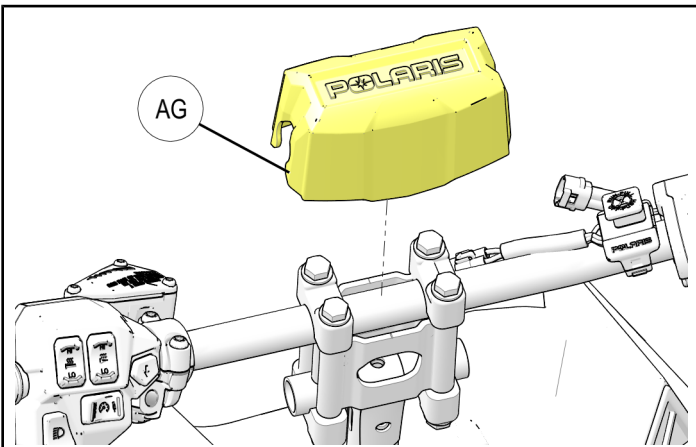

8. Remove the belt removal tool (H), the four push darts (J) and two fasteners (K) shown below. Use T40 Torx® for fasteners (K) removal.

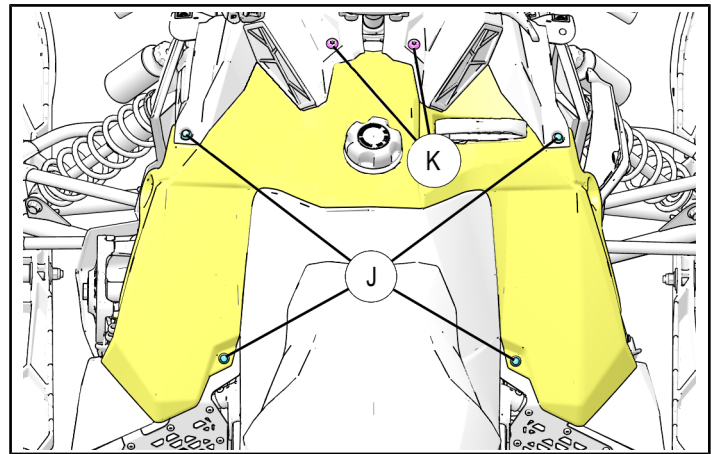
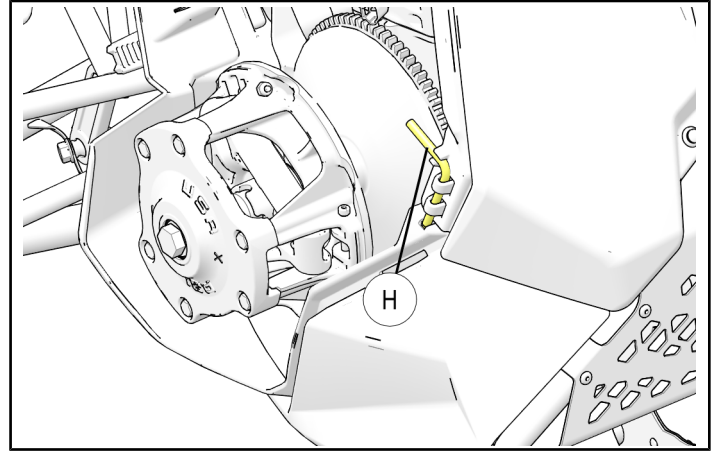

9. Remove the fuel cap (L) and filler neck nut (M). After removing the nut remove the console, then reinstall the fuel tank cap.

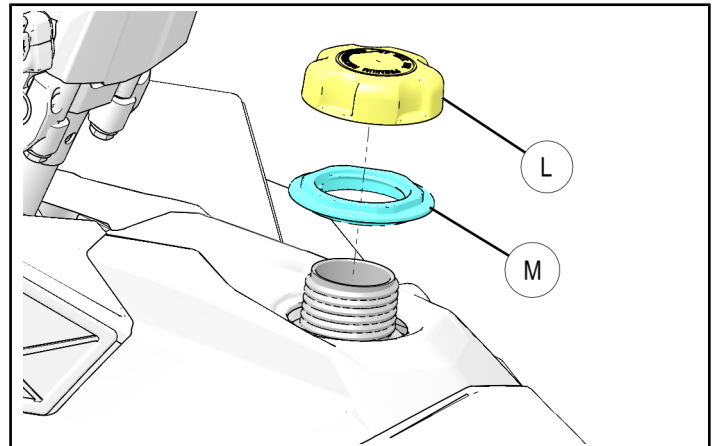

10. Locate the handlebar wire connector protective bag (N). Cut the zip tie (P) holding wires in place inside the bag (N).

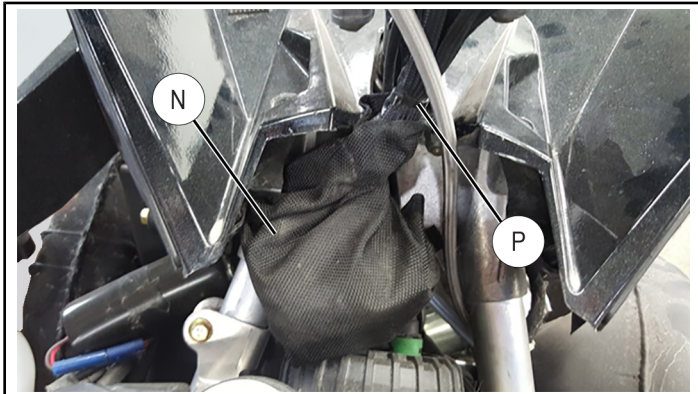

11. Pull the connectors out and locate the hand warmer connectors (Q), shown below, and disconnect them.

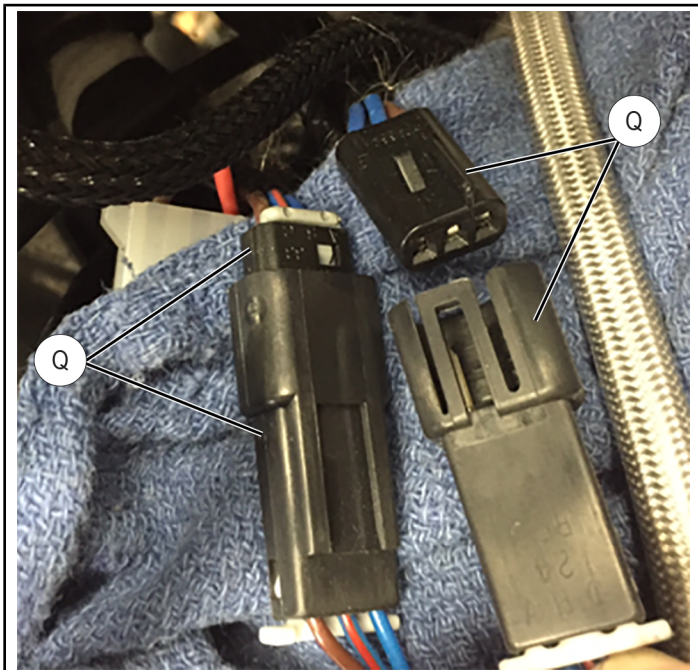

12. Use a needle-nose plier to extract the throttle cable barrel out of the throttle lever.

13. Loosen the set screw (R) of throttle block (S).

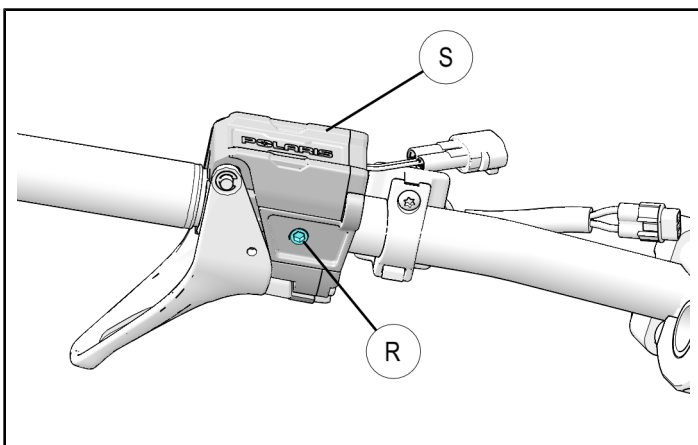

14. Remove e-clip (T), throttle lever pin (U) and adjustment washers (V). Note the number of washers. Remove throttle lever (W).

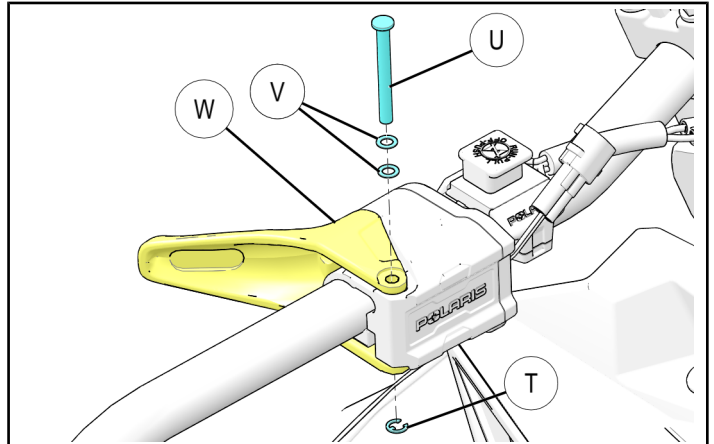

15. Remove the screw (X) from auxiliary stop switch block (Y). Remove or reposition the stop switch assembly to gain access the cover screws.

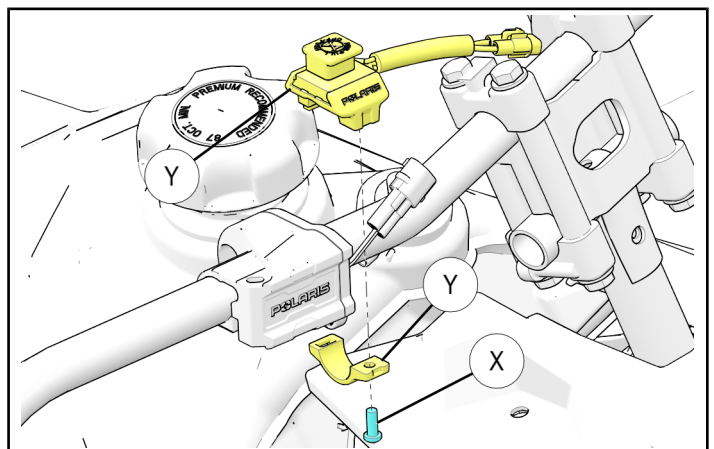

16. Remove throttle block cover by removing four screws (AH).

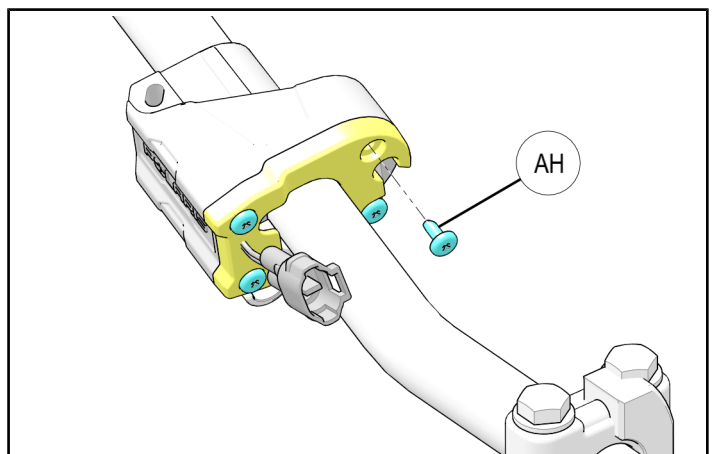

17. Remove throttle release switch (Z) from the throttle block. Note the orientation of the switch.

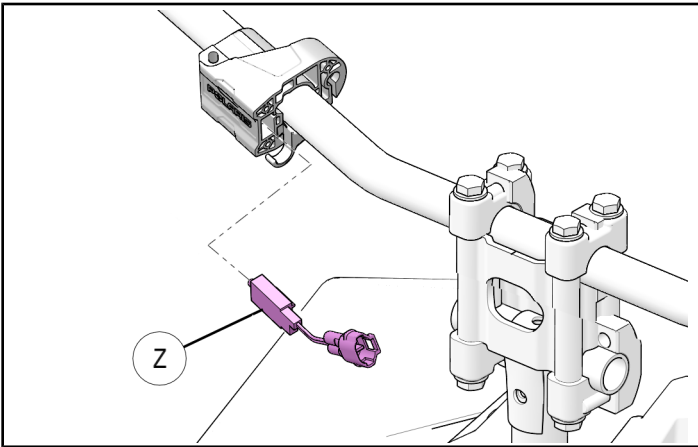

18. Slide the lower block out of the upper block. Remove the throttle blocks (S) from the handlebar.

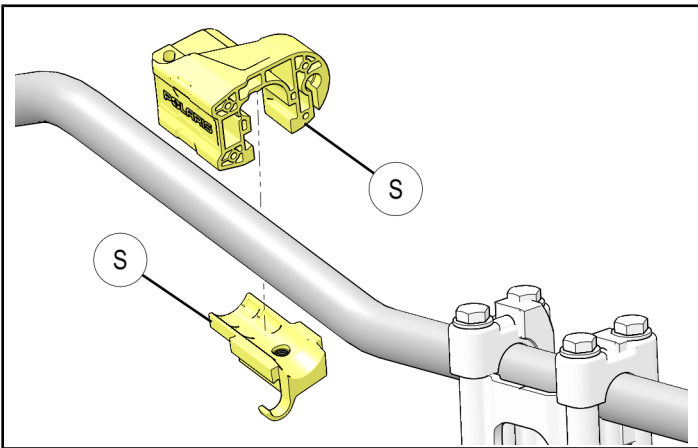

19. Remove the brake master cylinder (AA) by removing two screws (AB). Use T30 Torx® for screws (AB) removal.

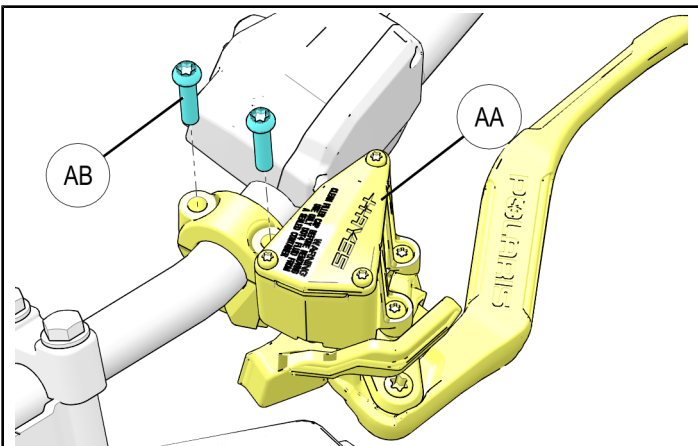

20. Remove the LH control (AC) by removing four screws (AD) from rear. Use T20 Torx® for removing screws (AD).

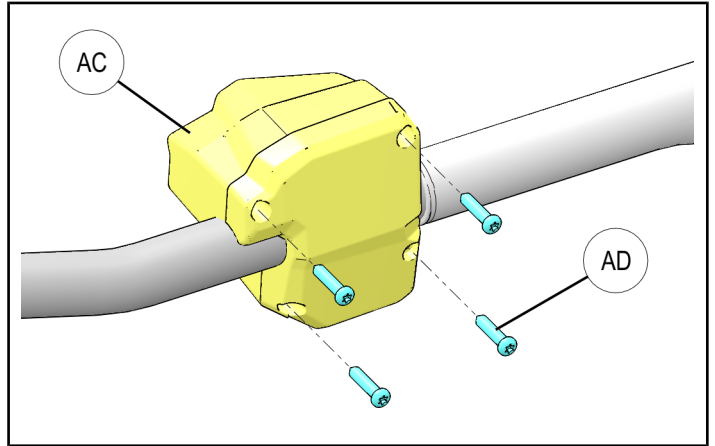

21. Remove two clamps (AJ) holding the stock handlebar (AF) in place by removing four bolts (AE) using a 13mm wrench. Remove the stock handlebar (AF).

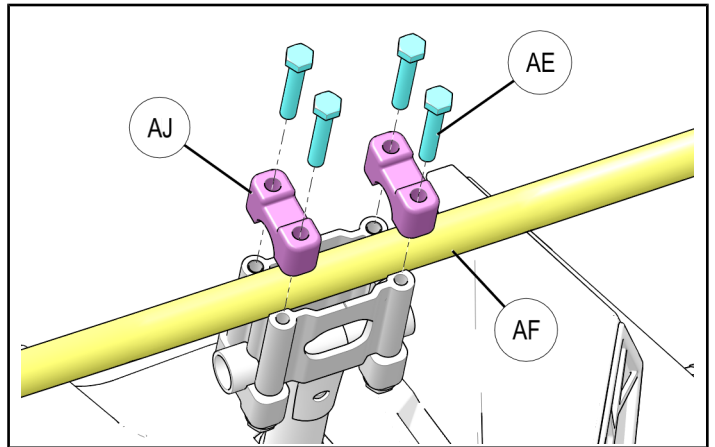

INSTALLATION

1. Install the new handlebar ④ onto the block mount. Install clamps (AJ) screws (AE). Torque screws (AE) to specification.

TORQUE

14.8 ft. lbs. (20 Nm)

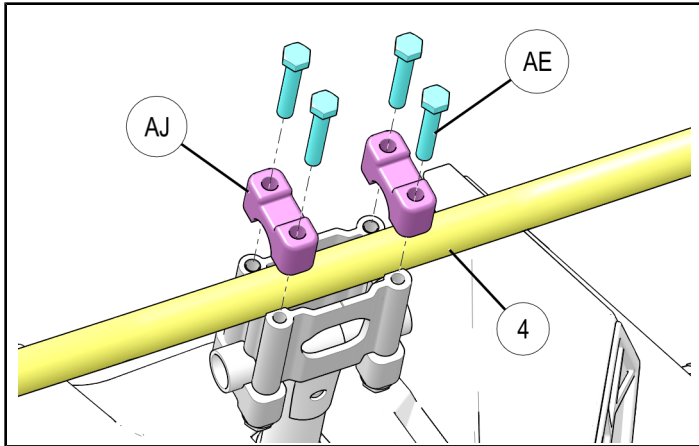

2. Connect both hand warmer connectors ② ③, place all connectors back in protective pouch (N) close and install Panduit strap (P) to the top of the bag.
3. Replace the LH control (AC) and hand tighten the four Torx® screws (AD).
4. Replace the brake master cylinder (AA) and torque the bolt (AB) furthest from the cylinder then tighten the bolt closest to the cylinder to specification.

TORQUE

70 in. lbs. (7.9 Nm)

5. Reinstall the throttle blocks (S) to the handlebar. Slide the lower block into the upper block.
6. Reinstall the throttle release switch (Z) in proper orientation onto the throttle block (S).
7. Reinstall the screw (X) to auxiliary stop switch block (Y) and torque to specification.

TORQUE

12 in. lbs. (1.4 Nm)

8. Reinstall throttle lever (W) by installing e-clip (T), throttle lever pin (U), and adjustment washers (V).
9. Tighten the throttle block set screw (R) to specification.

TORQUE

27 in. lbs. (3.1 Nm)

10. Fix the throttle cable barrel back to the throttle lever (W).
11. Reinstall the throttle block cover using four screws (AH). Torque screws to specification.

TORQUE

6 in. lbs. (0.7 Nm)

12. Replace console, insert four push darts (J) two screws (K) and the belt removal tool (H).
13. Replace hood (E) and side panels (C).
14. Install new handlebar cover ①.

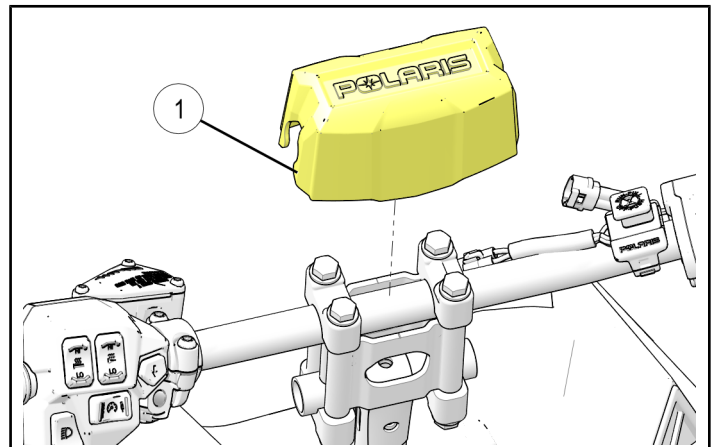

15. Insert new grips ⑤ on both sides of handlebar.