

VERSA TOURING PASSENGER SEAT KIT



P/N 2882791;2882801

APPLICATION

Verify accessory fitment at Polaris.com.

BEFORE YOU BEGIN

Read these instructions and check to be sure all parts and tools are accounted for. Please retain these installation instructions for future reference and parts ordering information.

KIT CONTENTS

NOTE

Full installation of this kit also requires the following additional parts (sold separately):
Versa Rear Cargo Rack, **PN 2882792**

This Kit includes:

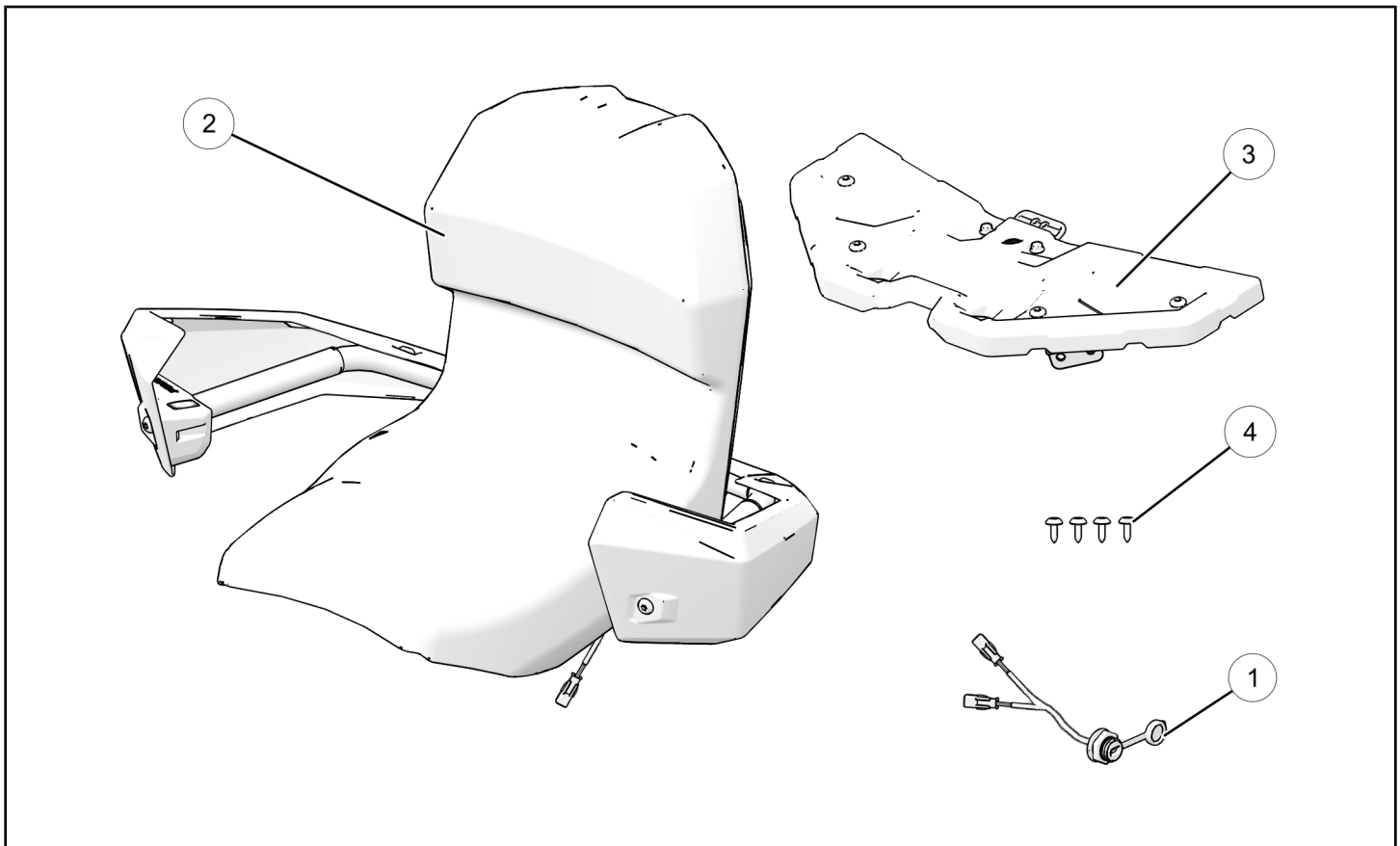

REF	QTY	PART DESCRIPTION	KIT PN 2882801	KIT PN 2882791
1	1	12V DC Power Harness Plug	2414238	2414238
2	1	Passenger Seat, Assembly Heated Passenger Seat, Assembly	- 2883273	2882420 -
3	1	Passenger Seat Support	2882737	2882737

REF	QTY	PART DESCRIPTION	KIT PN 2882801	KIT PN 2882791
4	4	Screw - M6 X 1.0 X 20, TXTH	7519112	7519112
	1	Instructions	9927945	9927945

TOOLS REQUIRED

- Safety Glasses
- Drill
- Hole Saw: 1"
- Pliers, Side Cutting
- Socket Set, Metric
- Wrench Set, Metric
- Socket Set, Torx® Bit
- Torque Wrench

IMPORTANT

Your Versa Touring Passenger Seat Kit is exclusively designed for your vehicle. Please read the installation instructions thoroughly before beginning. Installation is easier if the vehicle is clean and free of debris. For your safety, and to ensure a satisfactory installation, perform all installation steps correctly in the sequence shown.

ASSEMBLY TIME

Approximately 30 minutes

INSTALLATION INSTRUCTIONS

NOTE

Any previously installed accessories that may interfere with the installation of the Versa Touring Passenger Seat kit may need to be removed from the vehicle and set aside for later reinstallation before proceeding with this installation. See the installation manuals that accompanied previously installed accessory kits for details on removal and reinstallation.

1. Remove rear cargo platform by first removing two screws (A) from tail light (B) and remove tail light assembly by unplugging tail light from harness. Set aside for later use. Then remove the ten screws (C) securing the rear cargo platform to the vehicle and remove the rear cargo platform.

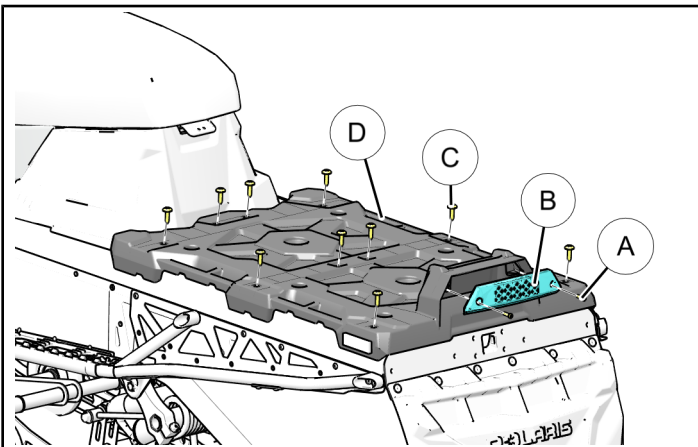

2. Next remove seat (E) to gain access to the fasteners securing the rear tank cover (H) in place. Remove fasteners (F) and (G) to remove rear tank cover (H) before drilling. Retain all fasteners for reinstallation.

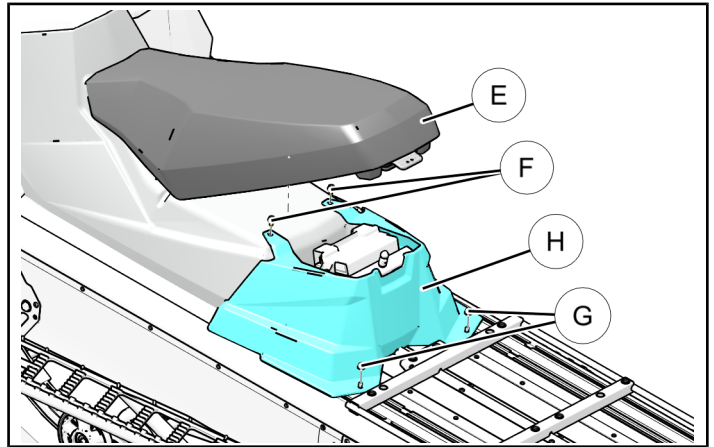

3. Carefully cut out hole location templates for step 4 from the last page of this instruction. Verify templates were printed to proper scale by using a ruler or tape measure to verify REFERENCE DIMENSION is exactly 4 inches.

IMPORTANT

If your measurement is not exactly 4 inches, then reprint template pages from electronic file using print setting "**Actual Size**" (not "Fit") to obtain proper 1:1 scale. Electronic file available from your **Authorized Polaris Dealer**.

- Place rear tank cover template **T** into position as shown and mark the location of the hole. Once marked, drill the required 1" hole in the rear tank cover.

CAUTION

DO NOT attempt to drill holes in rear tank cover without removing from vehicle as the battery is in close proximity to the inside of the cover. Failure to remove the cover before drilling may result in personal injury or damage to equipment.

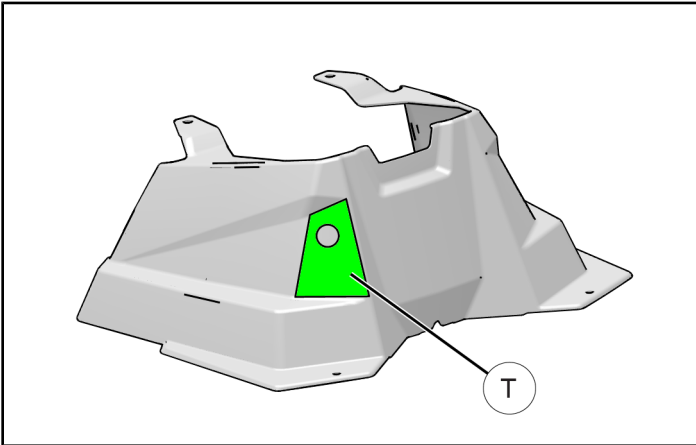

- After drilling, install 12V power harness plug **1** by removing the harness plug nut **H** and inserting the harness plug through the rear tank cover from the inside to the outside and secure with previously removed harness plug nut. Tighten nut enough to securely hold plug in place being careful not to overtighten.

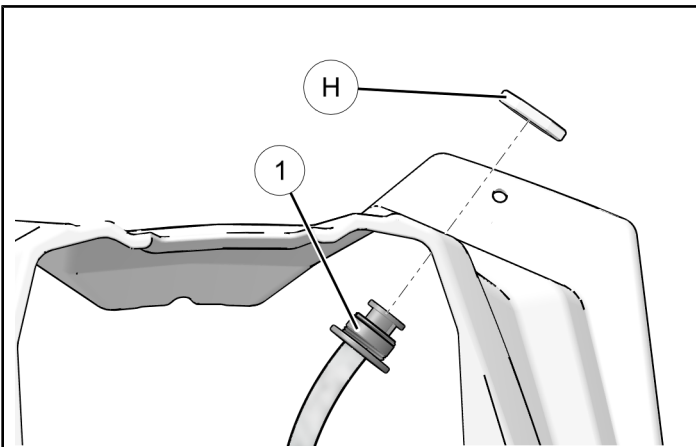

After installing harness plug, connect the white plastic female connector **J** to the mating connector **K** on the chassis harness as shown.

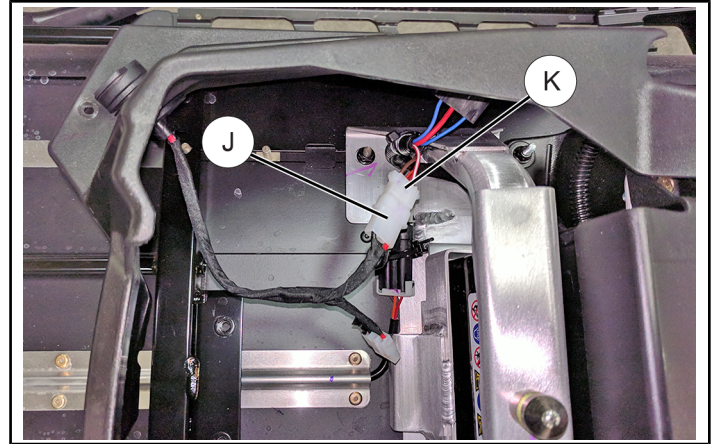

- Reinstall rear tank cover and torque all four fasteners to specification listed.

TORQUE

35 In. Lbs (4 Nm)

- Reinstall rear cargo platform and torque fasteners to specification listed.

TORQUE

8.5 Ft. Lbs (12 Nm)

- Install/Reinstall Versa Rear Cargo Rack Kit **PN 2882792**. See Versa Rear Cargo Rack instruction manual **PN 9927946** for installation instructions.

9. Place passenger seat support assembly ③ into position on the top of the Versa Rear Cargo Rack and fasten with the four supplied fasteners ④ as shown. Torque all seat support fasteners to specifications listed below.

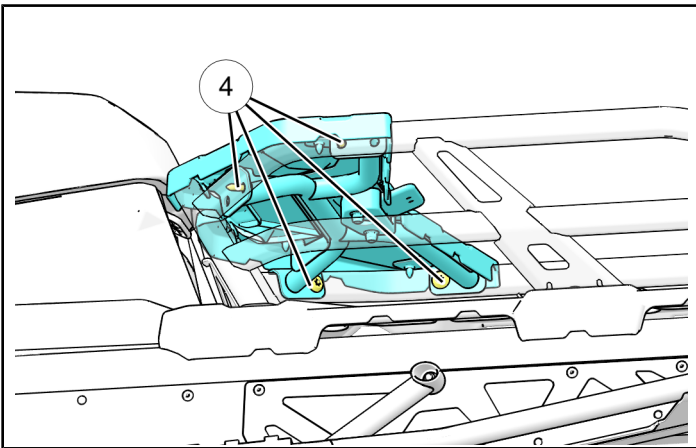
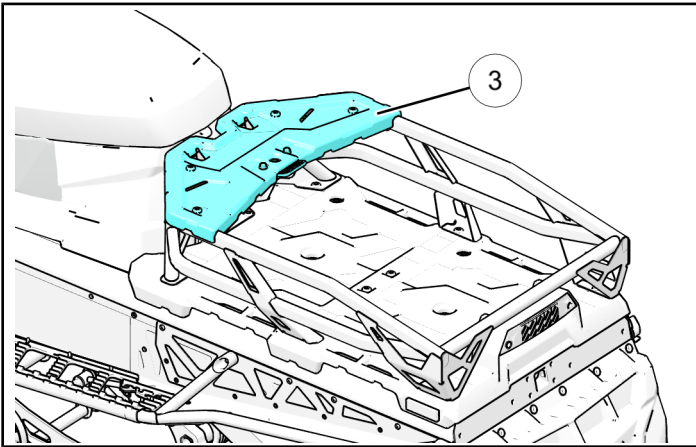

TORQUE

7.5 Ft. Lbs (10.5 Nm)

10. Install the passenger seat onto the vehicle by inserting the seat attachment hooks (L) on the bottom of the seat into the two attachment slots (M) in the seat support making sure they fully engage the upper front portion of the cargo rack.

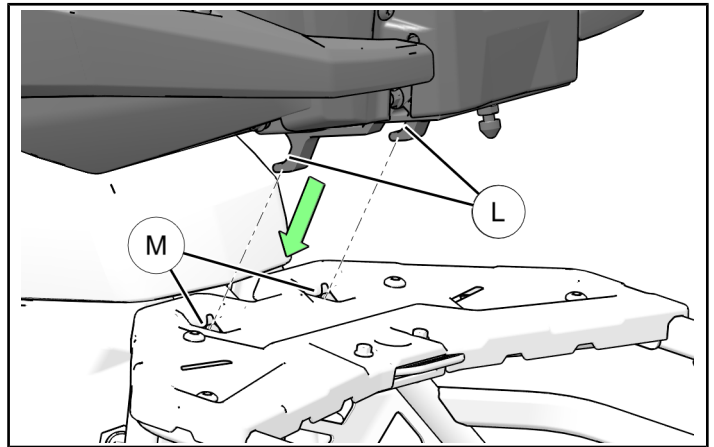

Once the front hooks (L) are engaged force the back of the seat assembly down until the latching pin (N) locks into the latching mechanism (P). Test to make sure the seat is fully secured by pulling on the hand holds and the seat back.

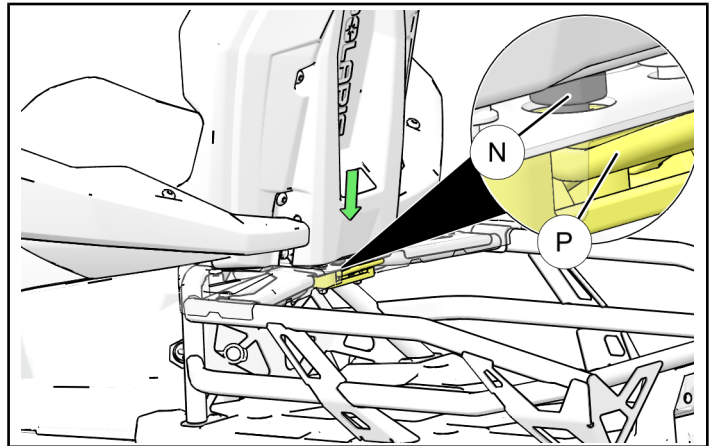

11. Once the seat is installed, plug in the seat harness (R) to the 12V power harness plug (1) as shown.

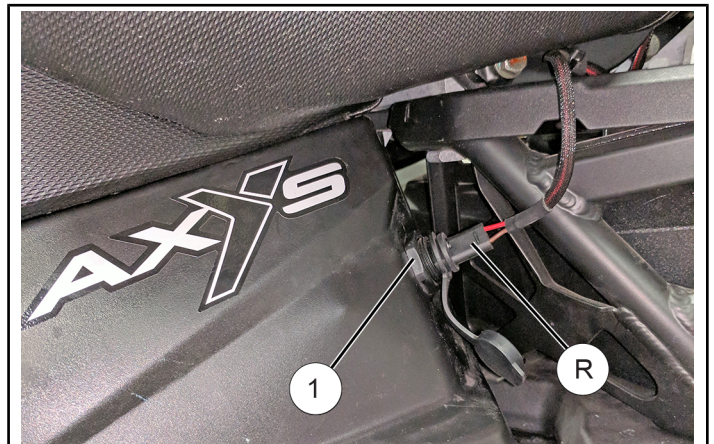

12. Ensure all tools are accounted for and all steps have been completed as required.

FEEDBACK FORM

A feedback form has been created for the installer to provide any comments, questions or concerns about the installation instructions. The form is viewable on mobile devices by scanning the QR code or by clicking [HERE](#) if viewing on a PC.



TEMPLATES

