

# ELITE FRONT BUMPER KIT



P/N 2881942-458; 2881942-133; 2881942-293;  
2881942-630; 2881942-647; 2881942-689

## APPLICATION

All Axys Models

## BEFORE YOU BEGIN

Read these instructions and check to be sure all parts and tools are accounted for. Please retain these installation instructions for future reference and parts ordering information.

## KIT CONTENTS

This Kit includes:

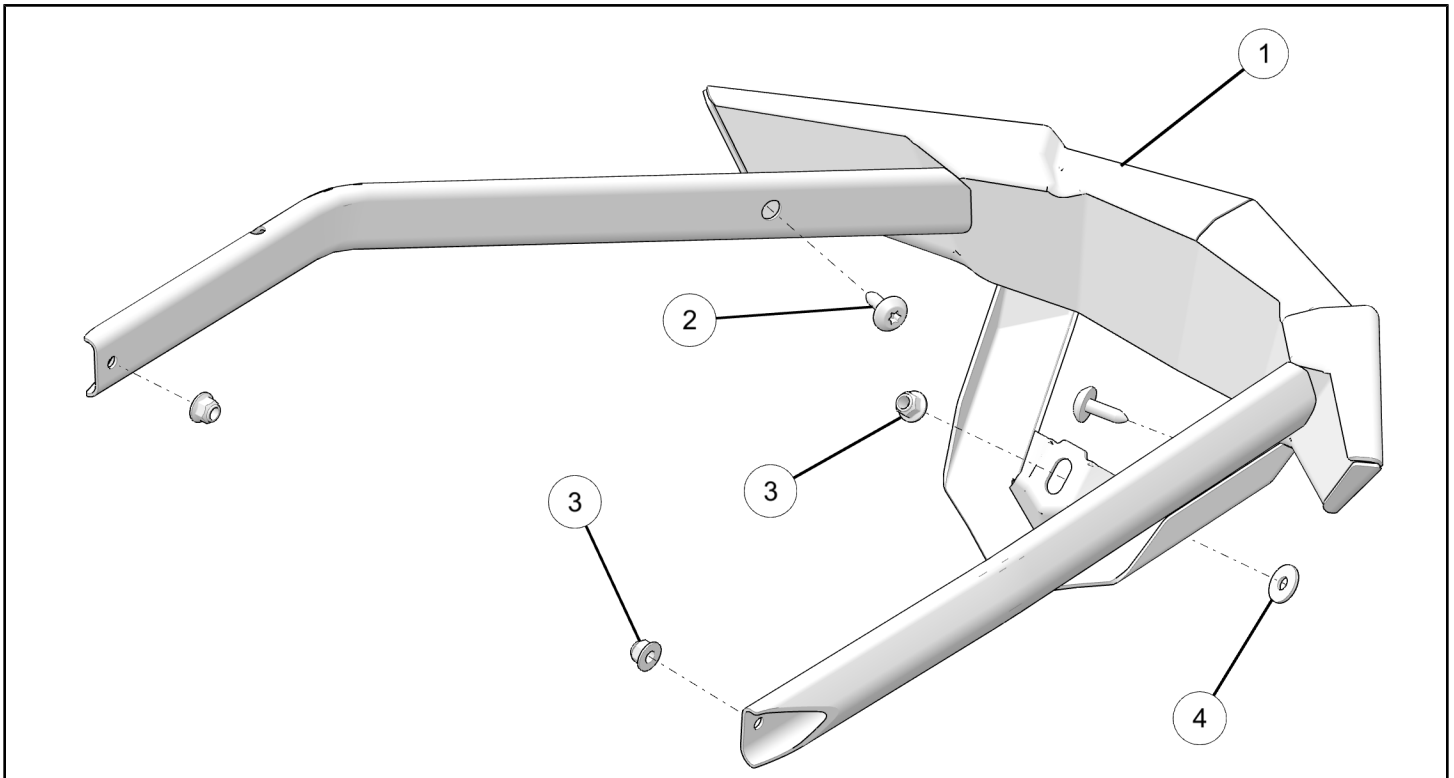

REF	QTY	PART DESCRIPTION	PART NUMBER
1	1	Front Bumper Assembly	1022962
2	2	Screw, Torx® - M6 X 1.0 X 20	7519112
3	3	Nut, Flange - M6 X 1.0	7547339
4	1	Washer - 6.4 X 18.0 X 1.6	7556064
	1	Instructions	9927063

## TOOLS REQUIRED

- T40 Torx® Bit
- 10mm Socket
- Spring Puller
- Torque Wrench
- 10mm Wrench
- Ratchet Wrench

## IMPORTANT

Your ELITE FRONT BUMPER KIT is exclusively designed for your vehicle. Please read the installation instructions thoroughly before beginning. Installation is easier if the vehicle is clean and free of debris. For your safety, and to ensure a satisfactory installation, perform all installation steps correctly in the sequence shown.

## ASSEMBLY TIME

Approximately 20 minutes

## INSTALLATION INSTRUCTIONS

### REMOVAL

1. Park the machine and turn the key to 'OFF' position. Remove the key from the vehicle.
2. Rotate the two 1/4 turn knobs (A) at the front and rear of the panel (C) and release the strap (B) at the lower edge of the panel.

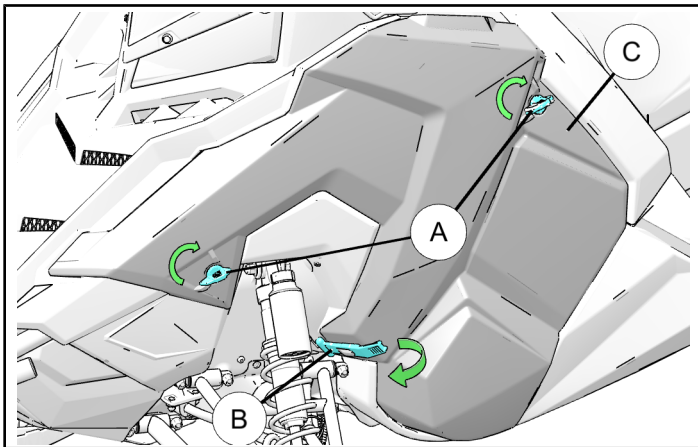

3. Open the side panel (C), then pull the panel outward to release the tabs at the bottom. Similarly, remove side panel on other side of vehicle.

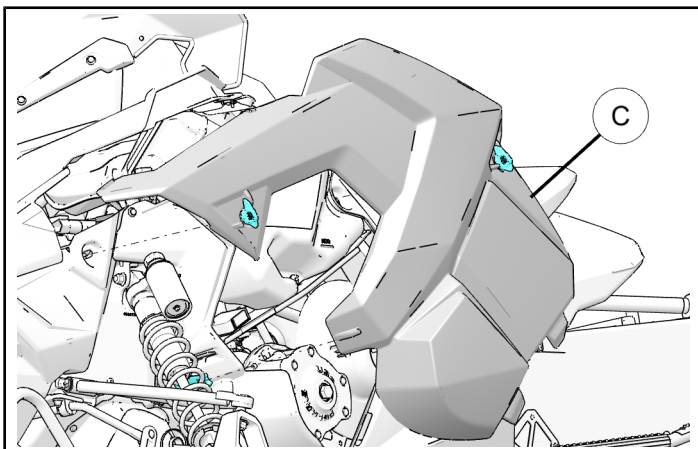

4. Rotate the 1/4 turn knobs (D) at the rear corners of the hood (E).

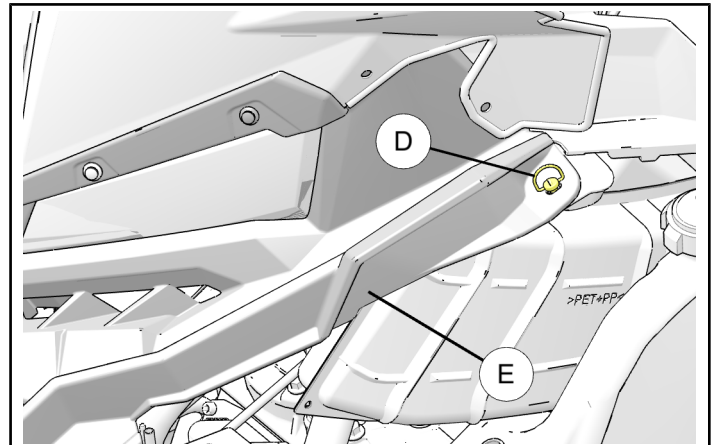

5. Disconnect the hood wire harness connector (F).

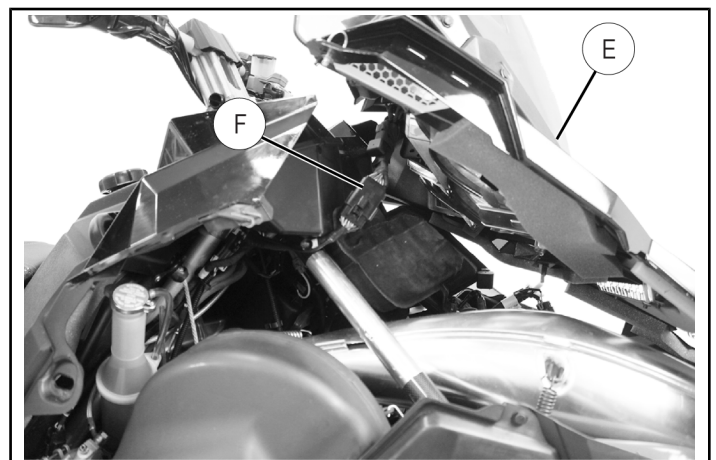

6. Remove the hood assembly (E) from the vehicle.

**NOTE**

Store the hood in a position that will not damage the brake cooler duct.

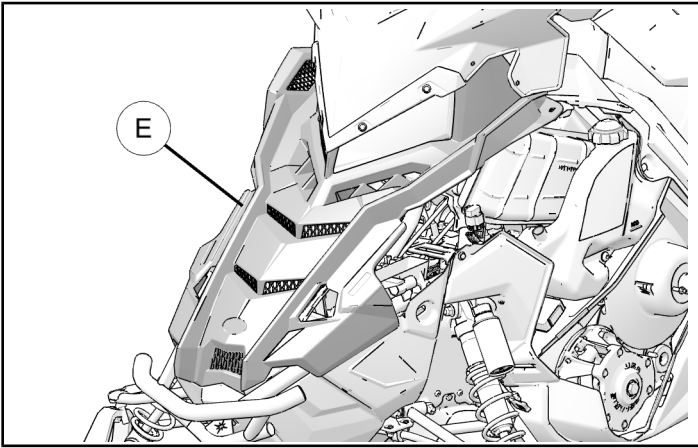

7. Using a commercially available spring removal/installation tool, remove the exhaust spring (H) connecting the front of the resonator to the chassis.

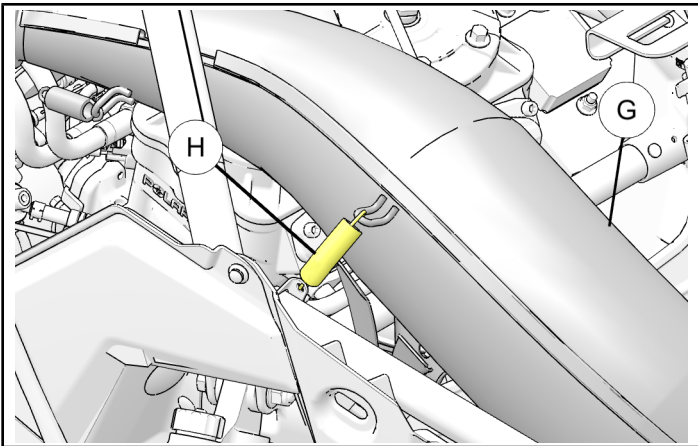

8. Remove two Torx® screws (J) securing left and right side of the bumper (K) to nose pan as shown. Discard the screws.

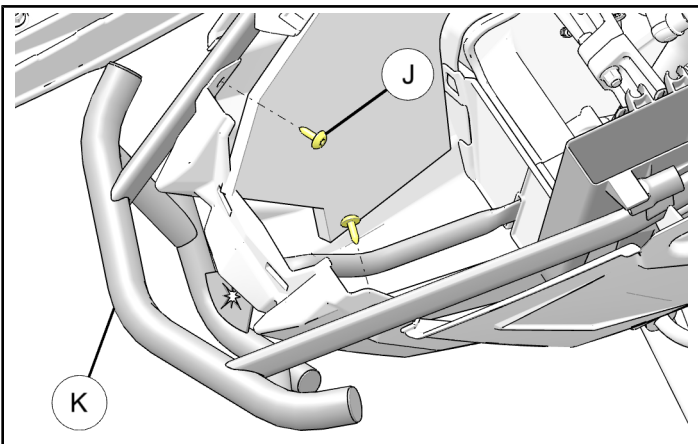

9. Remove two nuts (L) from bolts (M) using 10mm wrench and ratchet wrench. Retain bolts (M) for reuse and discard the nuts (L).

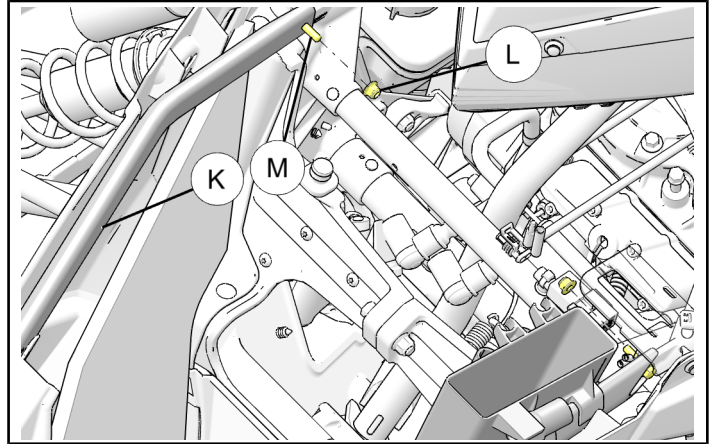

10. Remove nut (L) from bolt (P) holding bumper support (N) onto the nose pan. Retain bolt (P) for reuse and discard the nut (L).

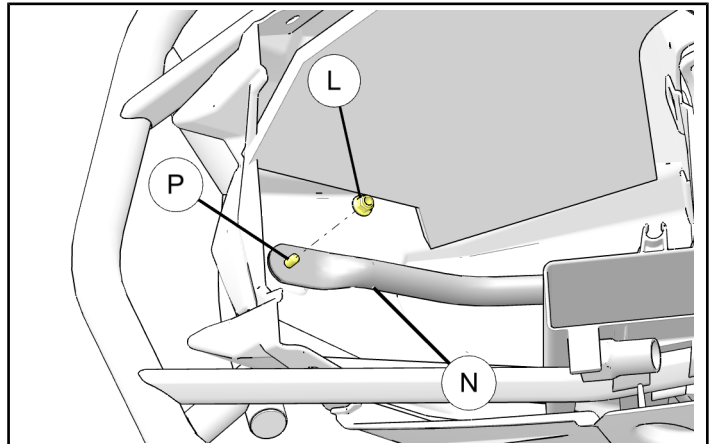

11. Unclip the spark plug tool (Q) and remove belt holder (R) from stock bumper (K).

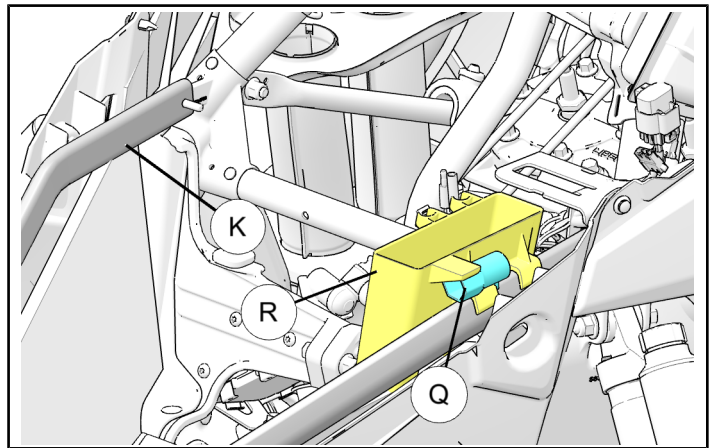

12. Remove stock bumper (J) from vehicle.

## INSTALLATION

1. Loosely install the left and right arms of bumper ① to the over structure mounts and install bolts (M) and nuts ③. Do not tighten hardware at this time.

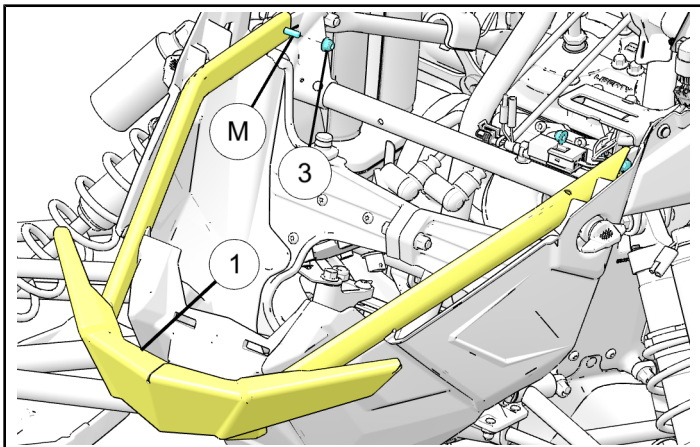

2. Install two Torx® screws ② and secure left and right side of bumper ① to the nose pan.

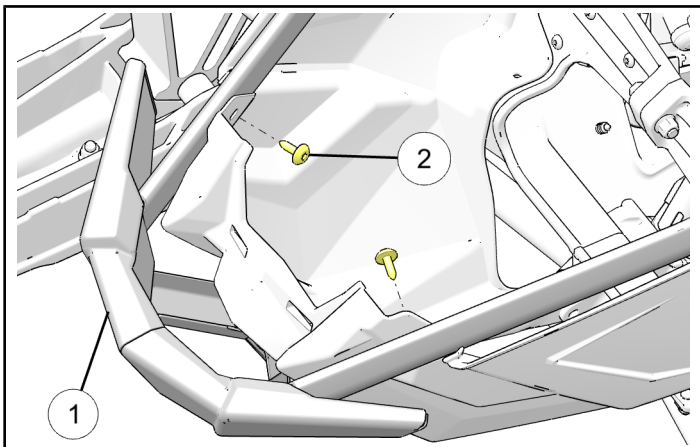

3. Insert retained bolt (P) through washer ④, front bumper ①, nose pan, and bumper support (N) and install nut ③ onto bolt (P).

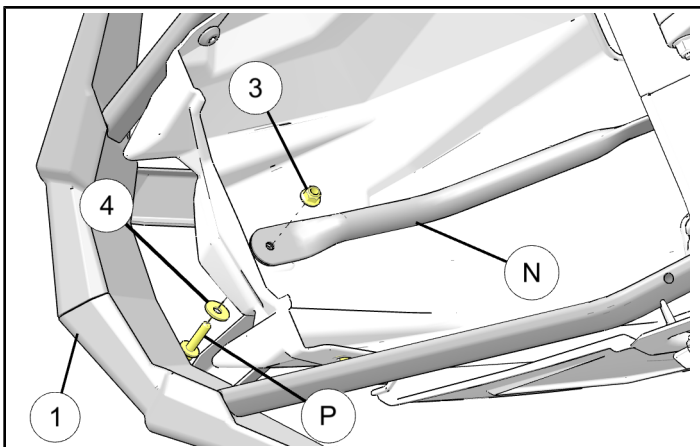

4. Tighten all fasteners to specification at this time.

### TORQUE

7.5 ft. lbs. (10 Nm)

5. Replace belt holder (R) on the new bumper ① and secure with the spark plug tool (Q).

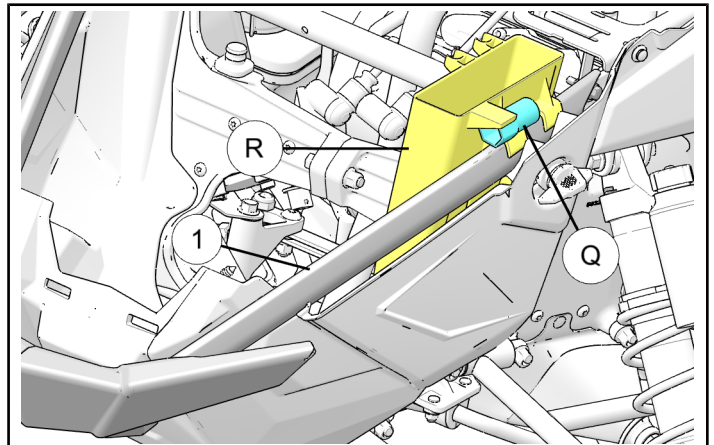

6. Reinstall exhaust pipe spring (H) removed in Step 7 of "Removal" section.
7. Reconnect the wire harness connector (F) and reinstall hood (E). Reinstall side panels (C).

### CAUTION

The hood and side panels protect the operator from moving parts. Never operate a snowmobile with the side panels open or removed. Always ensure that the hood and side panels are installed and securely latched before starting the engine.