

IQ RACK INSTALLATION KIT

P/N 2878156



POLARIS
The Way Out.®

Application

Polaris IQ 136

Before you begin, read these instructions twice and check to be sure all parts and tools are accounted for. Please retain these installation instructions for future reference and parts ordering information.

This kit includes:

Qty	Part Description	Part Number
1.....	IQ Rear Rack	1018149-067
1	Seat Mount	1017710-067
6.....	Carriage Bolts	7512298
4.....	Torx Head Bolts	7518235
6.....	Flat Washer	7556386
6.....	Nylok Nut	7542122
4.....	Flange Nuts	7542343
2.....	Nut	7547453
1.....	Instructions	9922911

Tools Required:

Torx Wrench (T-27)

10 mm Wrench

7/16 Wrench

IMPORTANT: For your safety, and to ensure a satisfactory installation, perform all installation steps correctly in the sequence as shown on the attached instructions.

INSTALLATION INSTRUCTIONS

1. Remove the four nuts and washers holding the seat support bracket to tunnel. Figure 1.
2. Lift back of seat up and pull back to remove seat from machine.
3. Tip seat over on its top and lay on flat, clean surface. Remove rear support bracket from seat base. Save hardware for re-installation.

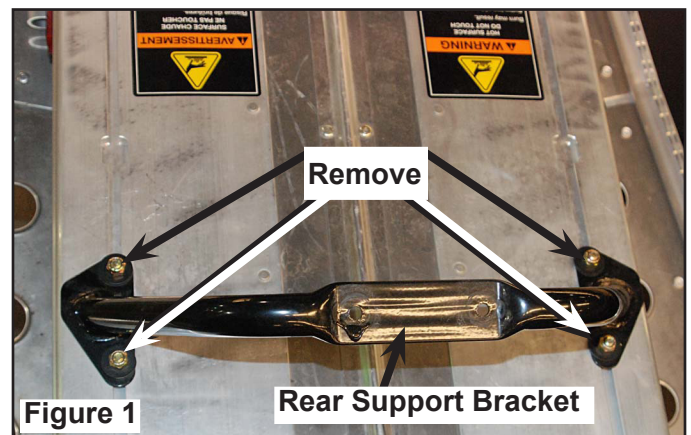

4. Slide front seat support bracket mounting bolts forward in slots approximately 2 ½" from existing location. Slide the rear mounting bolts back in slots approximately 1" from existing location. Install carriage bolts (PN 7512298) from kit in slot on each side and slide back from slot approximately 6 ½". Figure 2.

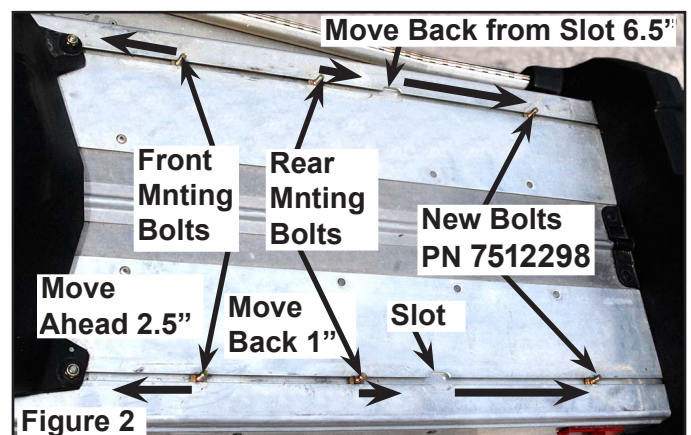

5. Align seat mount (PN 1017710) from kit to the front two mounting holes on rear rack. Insert the four bolts (PN 7518235) from the outside in. Install flange nuts (PN 7542343) and tighten to 18 ft lbs. (24 Nm). Install seat to mounting bracket using nuts (PN 7547453) from kit and tighten to 10 ft lbs. (13.5 Nm). Figure 3.

IMPORTANT: Care should be taken not to damage the seat while attaching the mounting bracket.

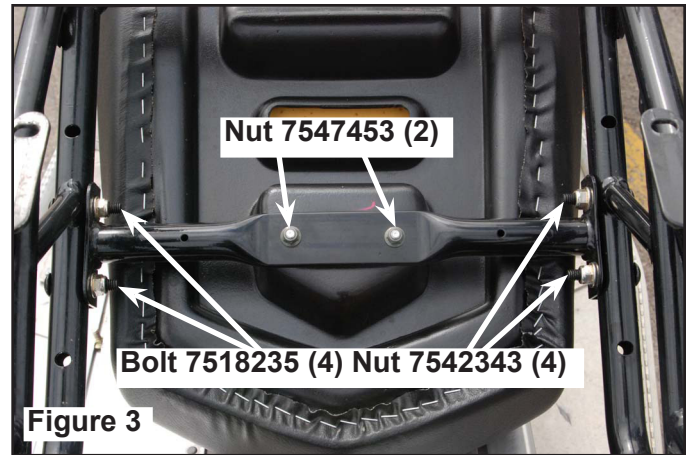

6. Lifting rack and back of seat up, slide the front of seat into the mounting bracket on fuel tank. Lower rack onto tunnel over mounting bolts. Figure 4. Push rack forward until front of seat is tight against fuel tank at mounting bracket.

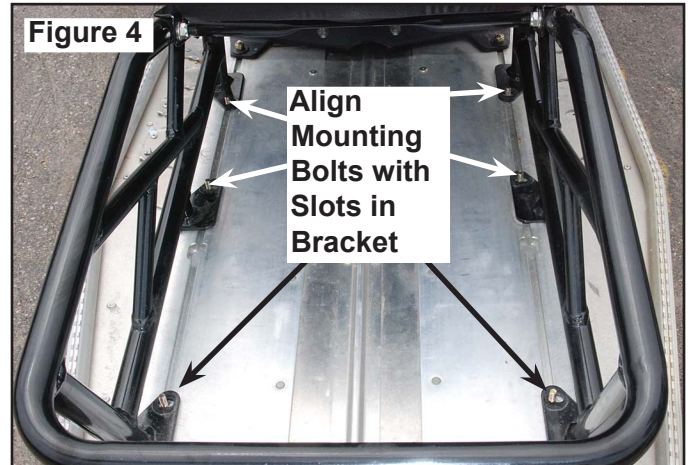

7. To secure rack, install six nuts (PN 754122) and six washers (PN 7556386) supplied in kit. Tighten to 10 ft. lbs. (13.5 Nm).
8. Make sure front of seat is tight against fuel tank seat mounting bracket before tightening down rack. Figure 5.

