



POLARIS RZR DOORS (P081202) INSTALLATION INSTRUCTIONS

Patent # D659,062 S

⚠ WARNING

Pro Armor Doors are designed to work together to replace your original equipment doors. Install the Pro Armor Doors to meet occupant protection standards (ANSI/ROHVA-1 effective model year 2014).

If you have questions about your installation, are unable able to complete installation, or your door is not working correctly contact Pro Armor Customer Service or have an authorized dealer or trained technicians inspect your installation. Pro Armor recommends you do not use your UTV if installation of the Door, and Slam Latch Kit is incomplete.

Pro Armor Doors are designed to work with the seat belt and other safety features provided by the manufacturer, along with proper preparation and responsible driving from the driver. Pro Armor recommends you follow all manufacturer's instructions when preparing to ride and during operation.

If you have any questions contact us at 1-888-312-7667 or WWW.PROARMOR.COM

PARTS LIST:

PART	DESCRIPTION	QTY
1	DOOR FRAME (LEFT)	1
2	DOOR FRAME (RIGHT)	1

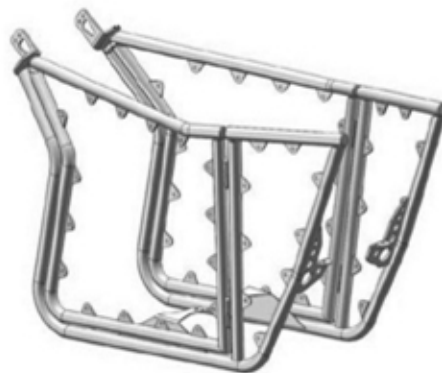

HARDWARE KIT:

ITEM NO.	PART NUMBER	DESCRIPTION	QTY.
1	HDWN0003	NUT, 3/8-16 NYLOC HEX ZINC	4
2	HDWB0197	BOLT, 3/8"-16 x 2.25", FLANGED HEAD HEX BOLT GR.	4
3	P081290-05	SLAM LATCH PIN W/JAM NUT 5/8-11	2
4	P081202-41	DRIVER SIDE SLAM LATCH BRACKET	1
5	P081202-40	PASSENGER SIDE SLAM LATCH BRACKET	1
6	HDWB0093	BUTTON-HEAD SOCKET CAP SCREW, M6 x 1 x 30MM ZINC PLATED	2
7	HDW00076	ROTARY LATCH, SINGLE CATCH, DRIVER SIDE	1
8	HDW00075	ROTARY LATCH, SINGLE CATCH, PASSENGER SIDE	1
9	J074809-44	KNOB	2
10	HDWB0251	BOLT, M6 x 16MM, BUTTON HEAD FLANGE, BLACK ZINC	50
11	HDWN0051	M6 x 1.0 ACORN FLANGED HEX NUT, BLACK ZINC, 4MM DEEP	50
12	HDW00009	ADHESIVE BACKED NEOPRENE RUBBER, 2"	8
13	P081202-45	A-PILLAR SPACER	2
14	HDWN0008	NUT, M6 X 1.0 NYLOC FLANGED HEX	8
15	HDW00000	PLAIN WASHER, 6MM, NARROW	4
16	HDWB0177	BOLT, M6 X 1.00 X 20MM BUTTON HEAD BOLT, BLACK ZINC	2
17	HDWB0050	BOLT, M6 X 1.00 X 30MM HEX HEAD BOLT	4
18	HDW00007	WASHER, M6, NARROW, BLACK ZINC	50

⚠ WARNING

Improper Use of Off-Highway Vehicles Can Cause Severe Injury or Death

Be Prepared

- Fasten seat belts.
- Wear an approved helmet and protective gear.

- Each rider must be able to sit with back against seat, feet flat on floor [and foot rests], and hands on steering wheel or handhold[s], where equipped]. Stay completely inside the vehicle.

Be Sure Riders Pay Attention and Plan Ahead

- If you think or feel the vehicle may tip or roll, reduce your risk to injury:
- Keep a firm grip on the steering wheel or handholds and brace yourself.
 - Do not put any part of your body outside of the vehicle for any reason.

NOTICE

During installation, the roll cage will be disconnected from the frame. Due to the construction of the vehicle, the frame can flex greatly, causing fitment and/or rubbing issues with the Doors. It is HIGHLY recommended to set the vehicle on 4 jack stands (taking full weight off the wheels) during the entire installation process.

PREPARATION TO INSTALL DOOR:

1. Remove the seats from the vehicle, along with side nets and side bar system.
2. Remove the forward mounting bolt and nut from the B-pillar mount of the vehicle's roll cage. Perform procedure on both sides of the vehicle. See fig. 1 (Rear mounting point)
3. Remove and retain the bolt that attaches the vehicle's floor plastics to the seat mount bar. Perform procedure on both sides of the vehicle. See fig. 2 (Mid mounting point)
4. Remove and retain the front mounting bolts and nuts from the A-pillar of the vehicle's roll cage. Perform procedure on both sides of the vehicle. See fig. 3 (Front mounting point)

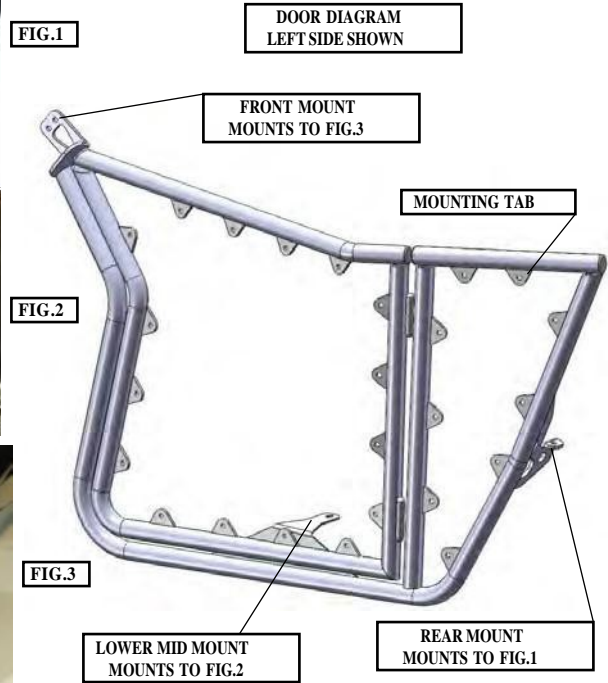

DOOR INSTALLATION:

1. Position the left side door in place on the left side of the vehicle. Align the rear mount of the door to the rear B Pillar mounting point. Loosely install with one of the retained mounting bolts from the front roll cage mount and the retained nut from the rear mount in Preparation step # 4.
2. Align the door's lower mid mount with the vehicle's mid mounting point and loosely re-install the retained mounting bolt from Preparation step # 3.
3. Align the (2) mounting holes of the door's front mount to the vehicle's A-Pillar front mounting location. Loosely install (2) 3/8-16 x 2.25" hex bolts and (2) 3/8-16 nuts. When all (3) mounting points are located with hardware loosely installed, you may shift the door to adjust it to your liking then tighten all mounting bolts and fasteners securing the left side door to the vehicle. Repeat procedure on the right side of the vehicle.

NOTICE

Due to the production variances and differing conditions of the frame, door adjustments may be necessary to avoid rubbing and proper fit. Ensure proper fit before continuing!

If adjustment is necessary, confirm all mounting points are secured. Gently pull on the door frame as shown to adjust position of the door in the frame.

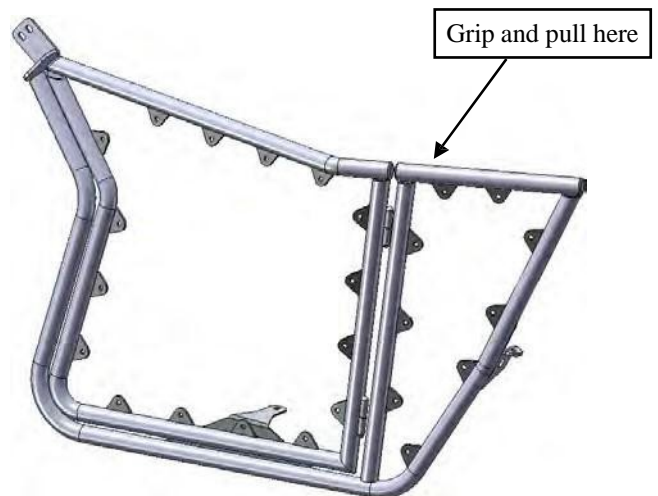

4. The remaining (50) M6 x 16mm button head bolts, (50) M6 nyloc nuts, (50) 6mm small washers and (50) 6mm large washers are to be used for installation of either the P081207 or P081209 Door Plates.

**** A video of Pro Armor's installation instructions can be found at our website (www.proarmor.com) or one of our skilled technicians (1-888-312-7667) will be happy to assist you if you have any questions. ****

For further information on RZR Door installation instructions and warnings please visit our website WWW.PROARMOR.COM or contact customer service at 1-888-312-7667.



SLAM LATCH INSTALLATION INSTRUCTIONS

PREPARATION AND INSTALLATION:

- The Slam Latches are designed to fit between the roll cage
A - Pillar and the aluminum bracket of the Pro Armor door frame.
- Lay out all of the components that come in the kit and verify that everything is correct according to the parts list.
- Take (12 or 13) one of the ROTARY LATCHES (8) two of the HEX HEAD BOLTS M6 X 1.00 X 25MM and (9) two ZINC HEX NUTS M6 X 1.0 installing the latch on one of the (1 or 2) SLAM LATCH BRACKETS (Driver or Passenger). Repeat process for latch in the other side.
- Remove and discard the two flanged head bolts that are currently installed in the Pro Armor door frame at the A-pillar of the vehicle (Driver or Passenger depending on what side you are installing.) Retain the 2 nuts.
- Place the SLAM LATCH BRACKET between the door and the A-pillar loosely installing (7) two of the FLANGED HEX HEAD BOLTS 3/8-16 X 2.25" from your Slam Latch kit, re-using the nuts from the A-pillar.
- Take (3) one SLAM LATCH PIN and (4) one 5/8" JAM NUT then screw the nut all the way on the pin leaving it loose. (Repeat for other pin.)
- Install the Slam Latch pin into the welded tab on the door until the door is able to close with out the pin interfering with the door frame bracket.
- Close the door so that the latch pin is fully locked and engaged making sure there is no play in the release lever.
- With the Slam Latch loosely installed you can now start to align the latch pin with the Slam Latch.

TOOL REQUIRED
14MM SOCKET & RATCHET - FOR CAGE BOLTS
14MM WRENCH - FOR CAGE BOLTS
10MM SOCKET & RATCHET - FOR SLAM LATCH BOLTS
10MM WRENCH - FOR SLAM LATCH AND BUTTON HEAD NUTS
5/8" WRENCH - FOR SLAM LATCH PIN
15/16" OR ADJUSTABLE WRENCH - FOR JAM NUT
4MM ALLEN WRENCH - FOR BUTTON HEAD BOLTS

ITEM NO.	PART NUMBER	DESCRIPTION	QTY.
1	HDWN0003	NUT, 3/8-16 NYLOC HEX ZINC	4
2	HDWB0197	BOLT, 3/8-16 x 2.25", FLANGED HEAD HEX BOLT GR. 8	4
3	P081290-05	SLAM LATCH PIN	2
4	P081202-41	DRIVER SIDE SLAM LATCH BRACKET	1
5	P081202-40	PASSENGER SIDE SLAM LATCH BRACKET	1
6	HDWB0177	BOLT, M6 X 1.00 X 20MM BUTTON HEAD BOLT, BLACK ZINC	2
7	HDWN0008	NUT, M6 X 1.0 NYLOC FLANGED HEX	8
8	HDWN0037	Jam Nut, 5/8"-11, Zinc Plated	2
9	HDW00076	ROTARY LATCH, SINGLE CATCH, PASSENGER SIDE	1
10	HDW00075	ROTARY LATCH, SINGLE CATCH, DRIVER SIDE	1
11	J074809-44	KNOB	2
12	HDWB0093	BOLT, M6 X 1.00 X 30MM BUTTON HEAD BOLT	2
13	HDW00000	PLAIN WASHER, 6MM, NARROW	4
14	HDWB0050	BOLT, M6 X 1.00 X 30MM HEX HEAD BOLT	4
15	HDWB0251	BOLT, M6 x 1.6MM, BUTTON HEAD FLANGE, BLACK ZINC	50
16	HDWN0051	M6 x 1.0 ACORN HEX NUT, ZINC	50
17	HDW00009	1" x 2" VIBRATION PAD	8
18	HDW00066	SINGLE USE RED THREAD LOCK	1

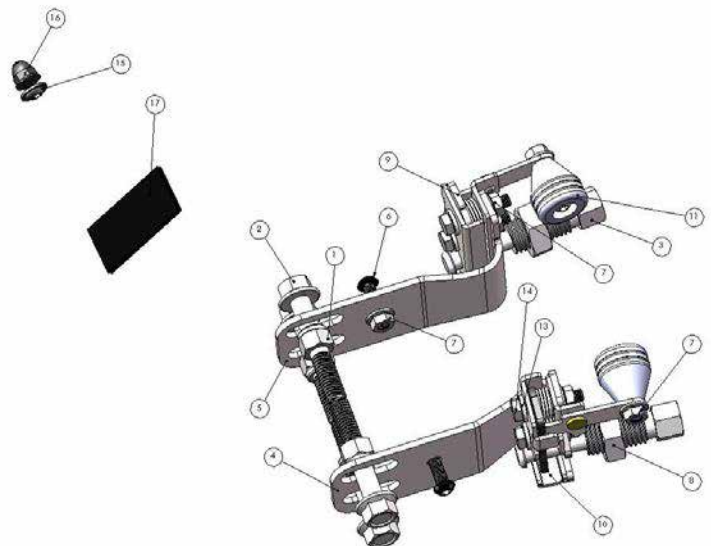

SIDE VIEW

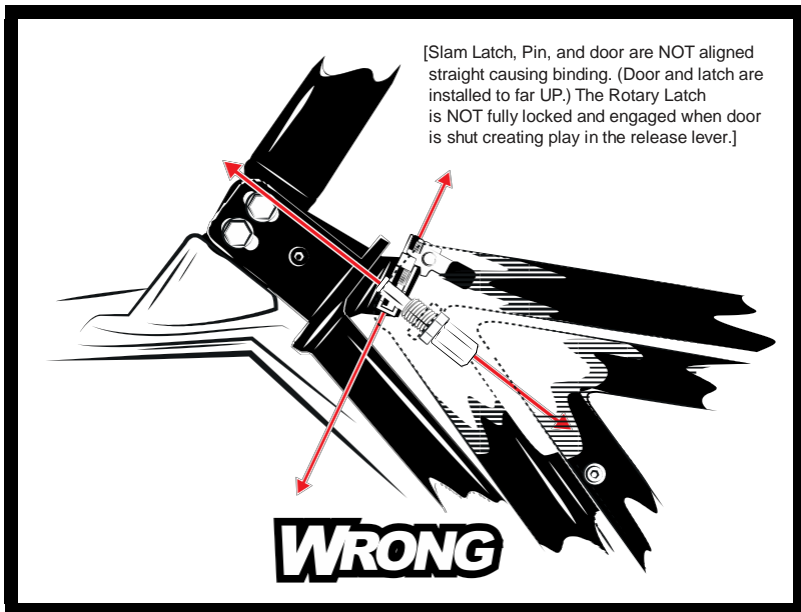
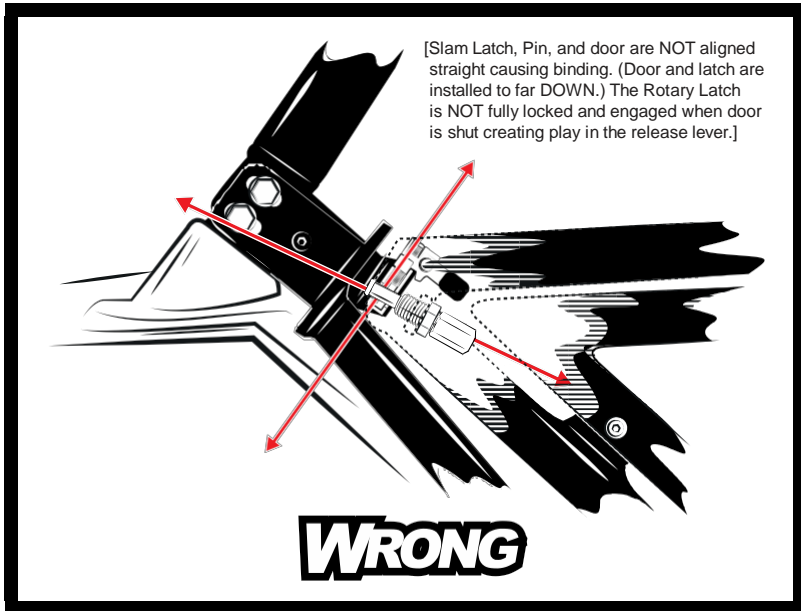
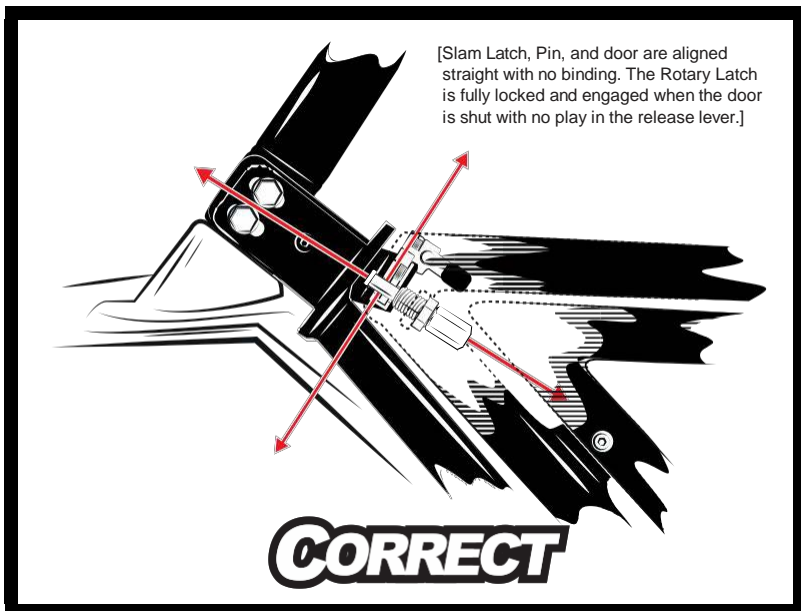

For further information on RZR Door installation instructions and warnings please visit our website WWW.PROARMOR.COM or contact customer service at 1-888-312-7667.

NOTICE

Adjust the latch pin by screwing it either in or out until the latch pin head protrudes through the slam latch but does not interfere with the door frame or the slam latch itself.

TOP VIEW

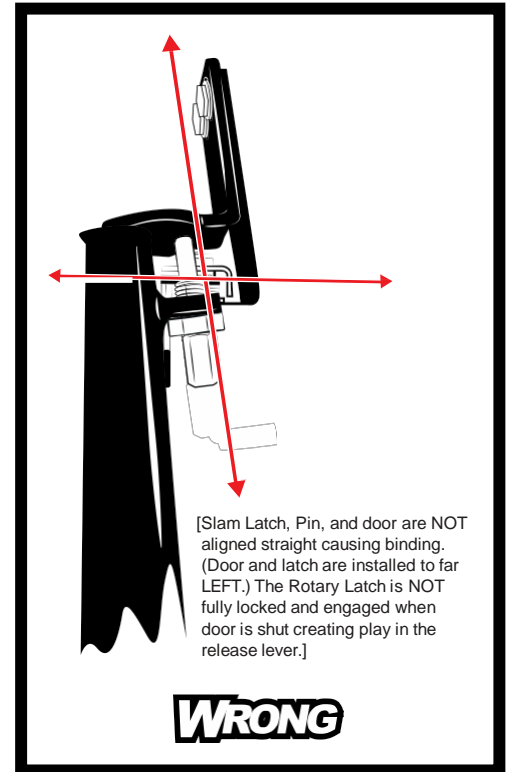
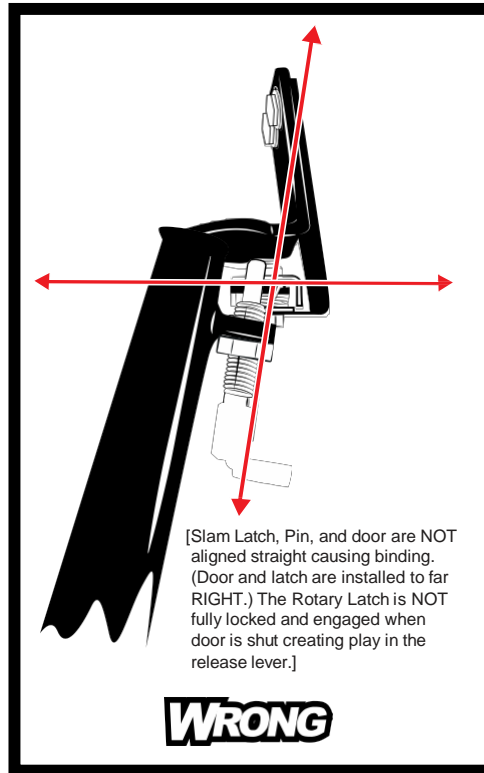
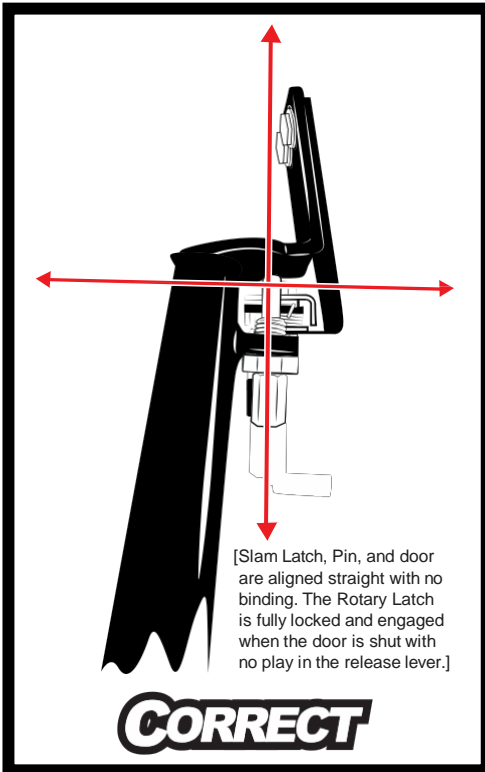

10. If needed move the slam latch bracket forward or backwards to align the latch pin.
11. With the door shut and no binding of the Slam Latch & pin begin tightening the (7) two FLANGED HEX HEAD BOLTS 3/8-16 X 2.25" at the A-pillar.
12. Tighten all of the hardware making sure to tighten the jam nut on the latch pin and all the hardware connecting the rotary latch to the slam latch bracket. Cycle the door open and shut to verify that the latch fully engages when the door is shut and that there is no binding. Once the final position of the bracket has been determined and the door functions properly you can drill a 1/4" hole into the aluminum door frame bracket at the A - pillar to match the hole provided in the slam latch bracket.
13. Once the hole is drilled take (5) one BUTTON HEAD BOLT M6 1.00 X 25MM and (6) one NYLOC FLANGED HEX NUT M6 X 1.0 installing them through the door frame bracket and the Slam Latch bracket.

NOTICE

- Check to be sure that the doors and vehicle frame are correctly aligned. If the doors and frame are not aligned properly, that latch pin and Slam Latch body may not be aligned and the latch pin may not fully engage and/or the door may not close completely. Inspect the doors and check to see that the latch pin and Slam Latch body are aligned properly and that the latch pin fully engages when the door shuts completely before each use.
- All screws and bolts should be tightened. Do not over-torque or bolts and screws may weaken or break.
- Inspect the Slam Latch, pin and parts to see that they are not cracked, bent, corroded, or otherwise damaged. Inspect the pin and latch to check that they are both fully operational.
- Have an authorized dealer or trained technician inspect the door alignment and Slam Latch after a collision or in the event of any damage.

For further information on RZR Door installation instructions and warnings please visit our website WWW.PROARMOR.COM or contact customer service at 1-888-312-7667.



POLARIS RAZR (P081208) DOOR SHEETS INSTALLATION INSTRUCTIONS

Please read these instructions carefully before installation to prevent injury to yourself or damage to your vehicle.

PARTS LIST:

PART	DESCRIPTION	QTY
1	DOOR SHEET (LEFT)	1
2	DOOR SHEET (RIGHT)	1
3	RIGHT REAR QUARTER PANEL	1
4	LEFT REAR QUARTER PANEL	1

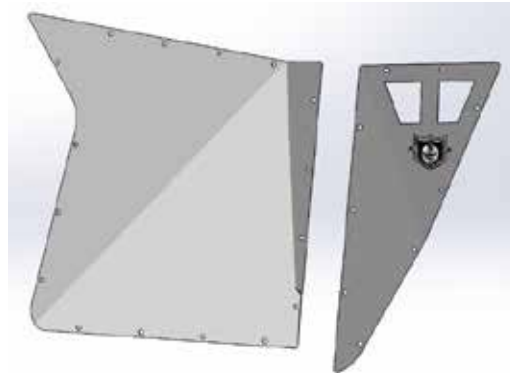

PREPARATION:

1. P081207 Door Sheets are to be installed with the P081202 Side door application. Please make sure that the side doors are properly installed on the vehicle. Locate the mounting hardware for the door sheets from the P081202 hardware kit. The hardware should consist of (50) M6 x 16mm button head bolts, (50) 6mm washers and (50) M6 acorn nuts.

INSTALLATION:

1. Position the left door sheet over the main swinging section of the left side door. Align the mounting holes of the door sheet to the mounting tabs located on the door. Loosely install (1) M6 x 16mm button head bolt, (1) 6mm washer and (1) M6 acorn nut at each of the mounting points. With all mounting points located and mounting hardware (16 each) loosely installed, tighten down the mounting bolts securing the left door sheet to the left door. See Fig. 1 and 2 below.
2. Repeat the procedure for the right door sheet on the right side door.

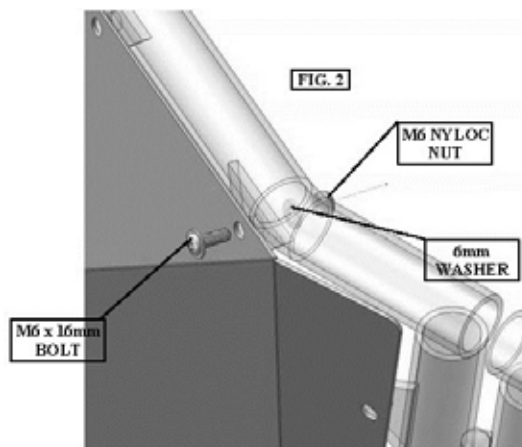
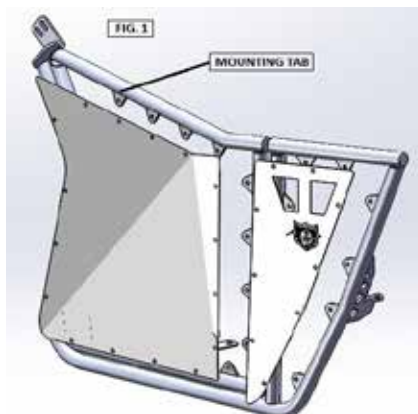

MAINTENANCE:

Periodically check to see that the doors sheets are properly installed. Re-torque mounting bolts when necessary. **Do not operate the vehicle if any bolts or fasteners are loose or missing from the doors. Do not operate the vehicle with door(s) open!**

CUSTOMER SERVICE:

For further information, please contact Pro Armor at 1-951-343-9270.