



## Polaris XP1000 Door Inserts (P144210)

### Installation Instructions

#### ⚠ WARNING

Pro Armor Door and Net are designed to work together to replace your original equipment nets and/or door. Install both the Pro Armor Door and Pro Armor Net to meet occupant protection standards (ANSI/ROHVA-1 effective model year 2014). Use of nets may help keep you from sticking your arm out of the vehicle during a rollover.

If you have questions about your installation, are unable able to complete installation, or your door is not working correctly contact Pro Armor Customer Service or have an authorized dealer or trained technicians inspect your installation. Pro Armor recommends you do not use your UTV if installation of the Door, Net, and Slam Latch Kit is incomplete.

Pro Armor Door and Net are designed to work with the seat belt and other safety features provided by the manufacturer, along with proper preparation and responsible driving from the driver. Pro Armor recommends you follow all manufacturers' instructions when preparing to ride and during operation.

If you have any questions contact us at 1-888-[312-7667](tel:1-888-312-7667) or [WWW.PROARMOR.COM](http://WWW.PROARMOR.COM)

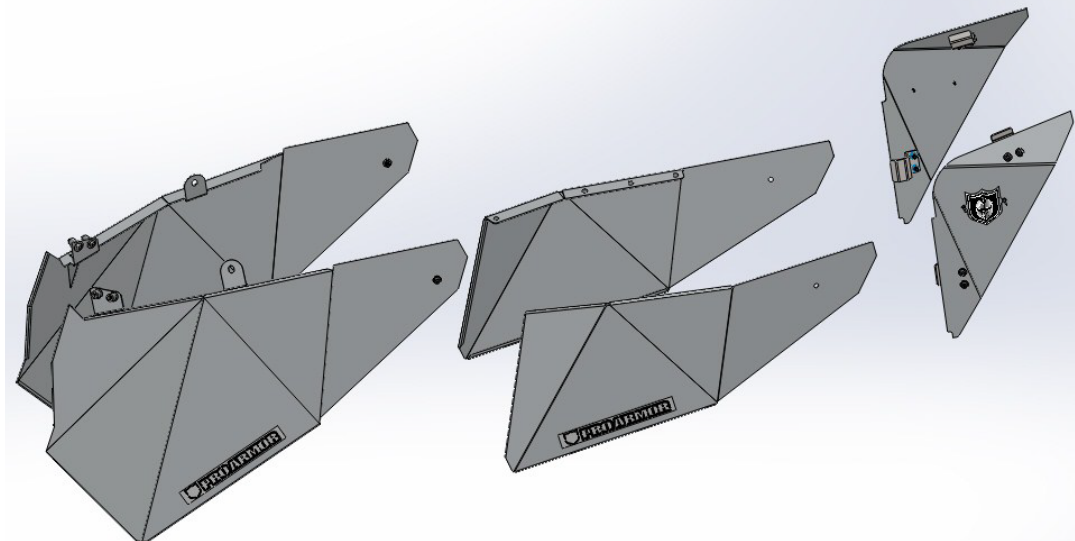

NOTE: DRILL, 1/2" AND 1/4" DRILL BIT NEEDED FOR INSTALL!!!

#### Disclaimer

Please read: This product is sold without warranty expressed or implied. No warranty or representation is made as to the products ability to protect the user / occupant from any injury or death in any manner of use. The user assumes that risk. The effectiveness of this equipment is directly related to the manner in which it is installed, used, and / or maintained. **Proper installation is solely the responsibility of the installer, and will not be assumed by Pro Armor.**

#### ⚠ WARNING

##### Improper Use of Off-Highway Vehicles Can Cause Severe Injury or Death Be Prepared

- Fasten seat belts.
- Wear an approved helmet and protective gear.

- Each rider must be able to sit with back against seat, feet flat on floor (and foot rests), and hands on steering wheel or handhold[s], where equipped]. Stay completely inside the vehicle.

##### Be Sure Riders Pay Attention and Plan Ahead

- If you think or feel the vehicle may tip or roll, reduce your risk to injury:
- Keep a firm grip on the steering wheel or handholds and brace yourself.
  - Do not put any part of your body outside of the vehicle for any reason.

For further information on RZR Door Installations and Warnings please visit our website [WWW.PROARMOR.COM](http://WWW.PROARMOR.COM) or

Contact customer service at 1-888-31-ARMOR

## NOTICE

Due to the production variances and differing conditions of the frame, door adjustments may be necessary to avoid rubbing and proper fit. Ensure proper fit before tightening hardware and continuing with installation! If adjustment is necessary, confirm all mounting points are secured. Gently pull on the front or rear door frames to adjust positioning of the door in the frame.

### HARDWARE LIST:

ITEM	DESCRIPTION	QTY
1	CLAMP BRACKET ASSEMBLY	4
2	BOLT, M6 X 16MM, BUTTON HEAD FLANGE, BLACK ZINC	20
3	M6 X 1.0 ACORN HEX NUT, ZINC	12
4	1/4"-20 RUBBER INSULATED BRASS RIVET NUT	4
5	BOLT, 1/4"-20 X 1" SOCKET BUTTON HEAD	4
6	WASHER, 1/4" FLAT ZINC COATED	4

PART	DESCRIPTION	QTY
1	FRONT DRIVER DOOR	1
2	REAR DRIVER DOOR	1
3	FRONT PASSENGER DOOR	1
4	REAR PASSENGER DOOR	1
5	HARDWARE KIT	1
6	DRIVER QUARTER PANEL	1
7	PASSENGER QUARTER PANEL	1

### Front Door Installation Instructions:



1. Open the stock door and remove the three(3) T25 Torx bolts circled in the pic to the left.
2. Drill out the front two(2) bolts that are close to each other with a 1/2" drill bit. TIP: DO NOT DRILL THROUGH THE PLASTIC PANEL ON THE BACK SIDE!
3. Insert two(2) item #2 Rubber Rivet nut into the 2 holes you drilled out, small side in first.

## NOTICE

- If the mounting hole alignment is off, you might need to use a jack to lift the vehicle. This will aid in aligning the holes. By lifting the middle of the vehicle, it will open the mounting area. And by lifting the front or the rear of the vehicle, it will close the mounting area.
- Due to the production variances and differing conditions of the frame, door adjustments may be necessary to avoid rubbing and proper fit. Ensure proper fit before tightening hardware and continuing with installation!
- If adjustment is necessary, confirm all mounting points are secured. Gently pull on the front or rear door frames to adjust positioning of the door in the frame.

For further information on RZR Door Installations and Warnings please visit our website [WWW.PROARMOR.COM](http://WWW.PROARMOR.COM) or Contact customer service at 1-888-31-ARMOR

USE THE DIAGRAM TO THE RIGHT SHOWING THE EXPLODED VIEW OF THE DOORS, HARDWARE AND PARTS USED TO INSTALL. THE HARDWARE IS NUMBERED ACCORDING TO THE HARDWARE LIST ON THE PREVIOUS PAGE.

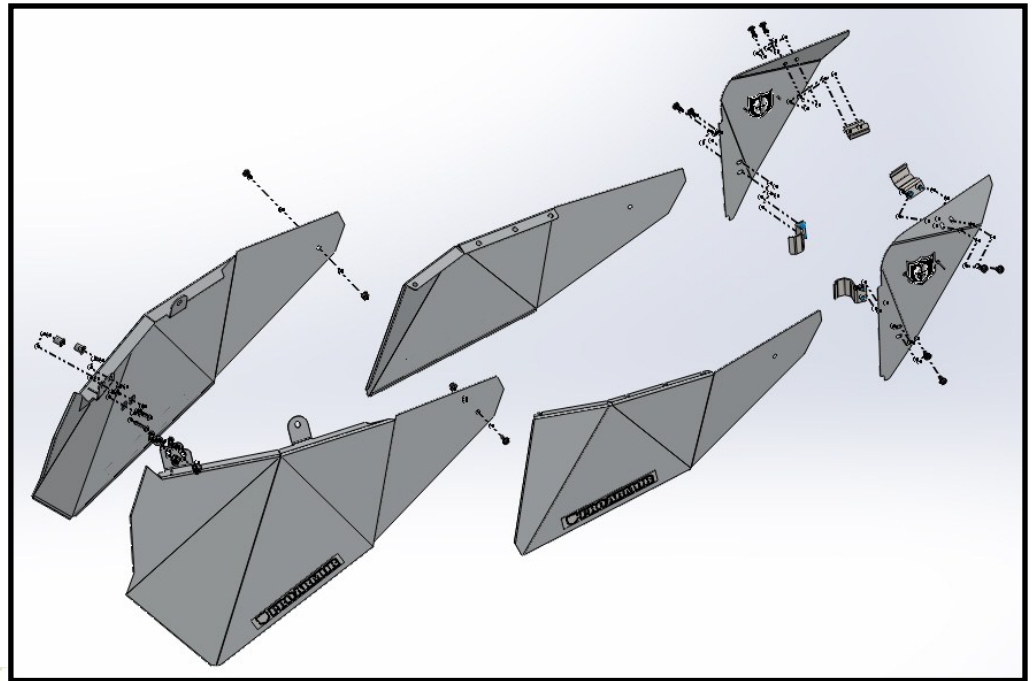

4. Place the door insert panel in place like shown on the figure to the left and hand tighten the three(3) inside bolts first. Use the supplied 1/4"-20 x 1" long bolts for the front 2 mount holes you drilled and inserted the rubber rivet nuts.

TIP: First install only 1 front bolt tight to help keep the second bolt from pulling out the rubber nut.

5. Once all three(3) of the inner bolts are in, fully tighten them, checking as you tighten to keep the gap between the panel and the plastic aligned best as possible.

6. Once all the inner bolts are tightened, use a marker or sharp item to mark the hole on the outside of the door and on the rear side. See figure to the right.

7. Insert item #1 M6 Bolt from the outside towards the inside and tighten on the back using item #4 Acorn nut.

8. Repeat steps for opposite side.



For further information on RZR Door Installations and Warnings please visit our website [WWW.PROARMOR.COM](http://WWW.PROARMOR.COM) or Contact customer service at 1-888-31-ARMOR

**REAR DOOR INSTALLATION INSTRUCTIONS:**

1. Place the rear door panel in place so the edges of the panel line up with the edges of the stock plastic door. See the figure to the right.
2. Hold the panel in place while you mark a couple of the holes. See figure to the right.

TIP: ONLY MARK TWO(2) HOLES AND DRILL FIRST. THIS WAY YOU CAN MOUNT 2 WITH THE HARDWARE SO THE PANEL WILL BE IN THE FINAL SPOT BEFORE MARKING ALL THE HOLES.

3. Once all the holes are marked use item #2(bolt) and item #3(nut) to secure the door insert to the stock plastic door.
4. With the door installed mark the plastic through the hole in the door insert on the outside and drill it out using a 1/4" drill bit through the stock door plastic.
5. Use items #2 & #3 to secure this rear tail section of the door insert to the stock plastic door.
6. Repeat steps to install opposite side.



## **QUARTER PANEL INSTALLATION INSRUCTIONS:**

TIP: LOOSELY TIGHTEN THE CLAMPS ON THE QUARTER PANEL ON SOFT FLOOR SO IT DOES NOT SCRATCH AND WILL MAKE THE INSTALL EASIER.

1. Use two(2) clamp bracket assemblies for each quarter panel. Loosely install the clamps on the quarter panel like shown on the figure to the right.

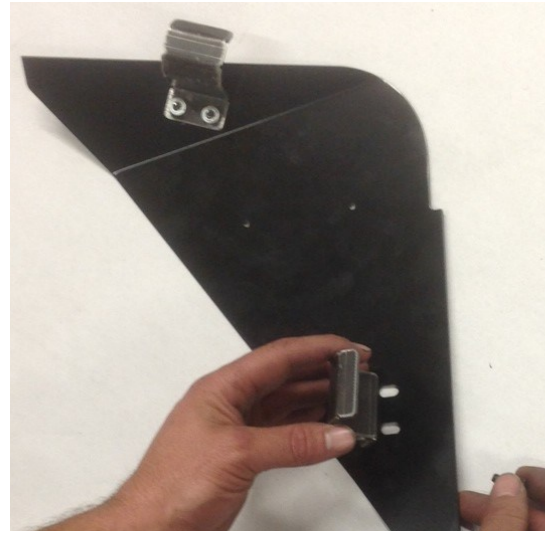

2. After loosely installing the clamps to the quarter panel, you can set it in place on the outside of the quarter panel tubes like shown on the figure to the left.

3. The panel should fit with all edges running parallel to the tubes that they are being mounted to. Once the gaps are good you can fully tighten all the bolts.

4. Repeat steps for opposite side.

NOTICE: Check all hardware before each us to ensure they are tight. If there are any issues please contact Pro Armor customer service using the information at the bottom of each page.

5. Repeat for opposite side.



**For further information on RZR Door Installations and Warnings please visit our website [WWW.PROARMOR.COM](http://WWW.PROARMOR.COM) or Contact customer service at 1-888-31-ARMOR**