



POLARIS XP1000 (P141524) TRAILING ARM GUARDS INSTALLATION INSTRUCTIONS

Please read these instructions carefully before installation to prevent injury to yourself or damage to your vehicle.

PARTS LIST:

ITEM NO.	PART NUMBER	DESCRIPTION	QTY.
1	P141524-01	PASSENGER SIDE PRE-PACKAGE ASSEMBLY	1
2	P141524-09	DRIVER SIDE PRE-PACKAGE ASSEMBLY	1

INSTALLATION:

1. Jack up the rear of the vehicle and place it on jack stands. Make sure to use a wheel chalk to keep the UTV from moving.
2. Remove both rear tires/wheels, sway bar bolts, and shock bolts that connect them to the trailing arm.
3. Place/slide the driver side guard over the driver side trailing arm from the bottom up. (keep this hardware)
4. Note– the cut outs go on the outside, since there is a left and right side!
5. Begin by using the existing hardware and run the sway bar bolts through the guard and through the trailing arm tabs.
6. Do the same for the lower shock mount bolt and install them hand tight.
7. Once the guard is on with both bolts, securely tighten both back to factory specs. (see vehicle's manual)
8. Repeat these steps to install the passenger side.
9. Once both guards are fully installed, install the tires to spec and lower the vehicle.

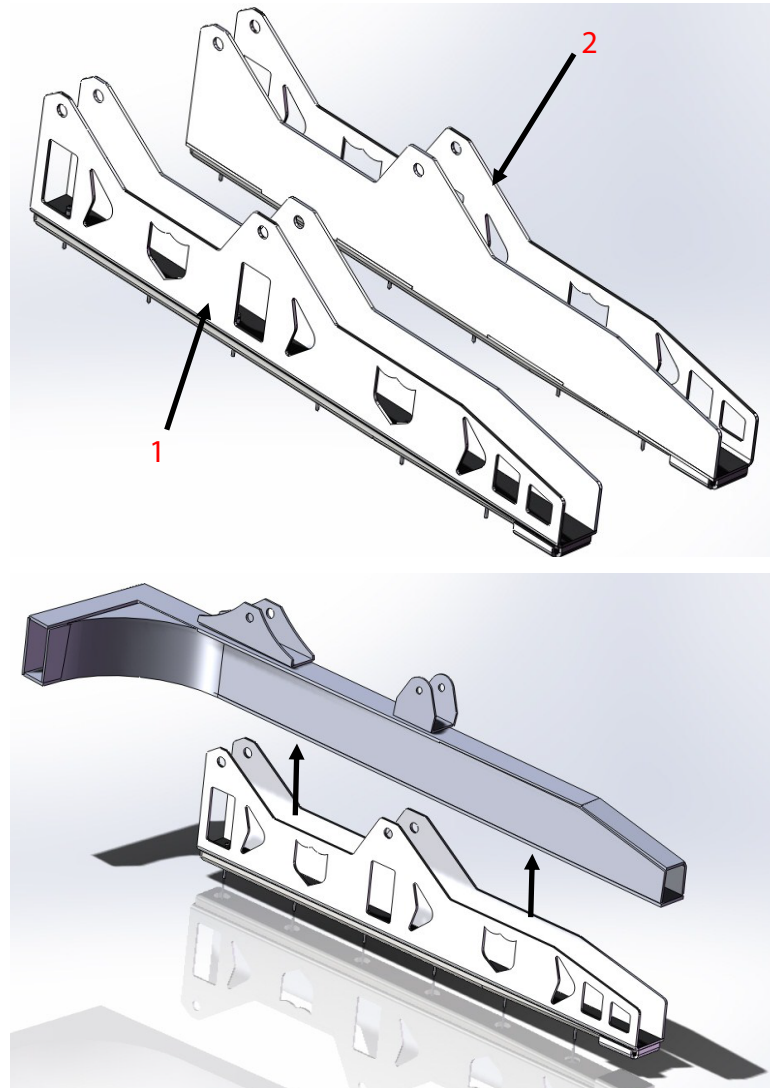

⚠ WARNING

— Be sure to check hardware before each use and make sure it is tight!

MAINTENANCE:

Periodically check to see that the trailing arm guards are properly installed. Retorque mounting bolts when necessary. Do not operate the vehicle if any bolts or fasteners are loose or missing.

CUSTOMER SERVICE:

For further information, please contact Pro Armor at 4951-343-9270.